



Scenic Automation

Nutshell Edition

Gareth Conner, May 2022

What's on the menu?

-  Creative Value of Automation
-  Pentagon of Power
-  Luck Favors the Prepared

Creative Value of Automation

Wash, Rinse, Repeat

Providing the audience with
the same show every night.

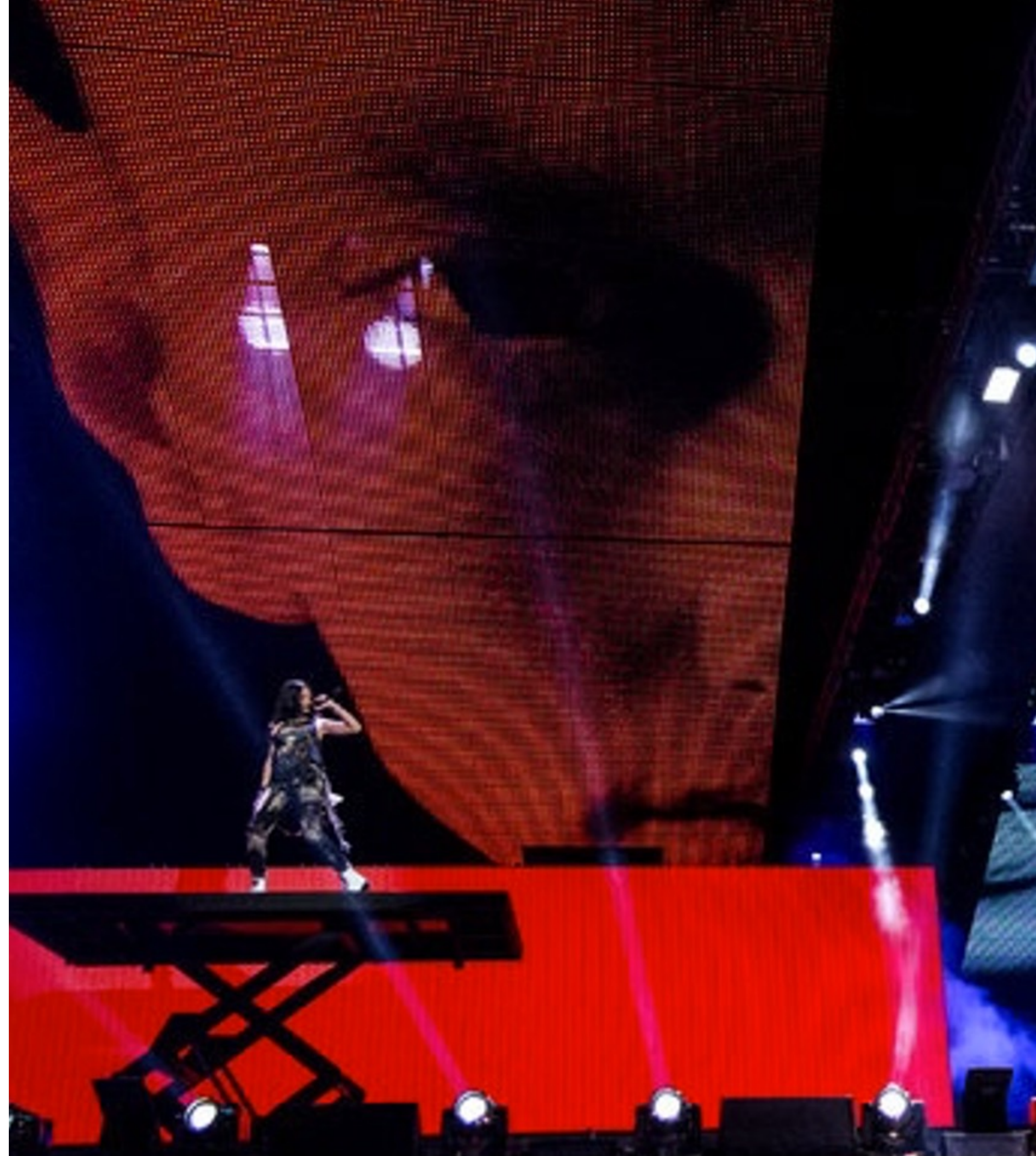

Speedy Delivery
Move fast and don't break
things.



Heavy Load

I pick things up and put them down.



Elegant Robots

Mechanical choreography
that advances the story.



Plays well with others

Coordinate motion with projection, lighting, and sound.

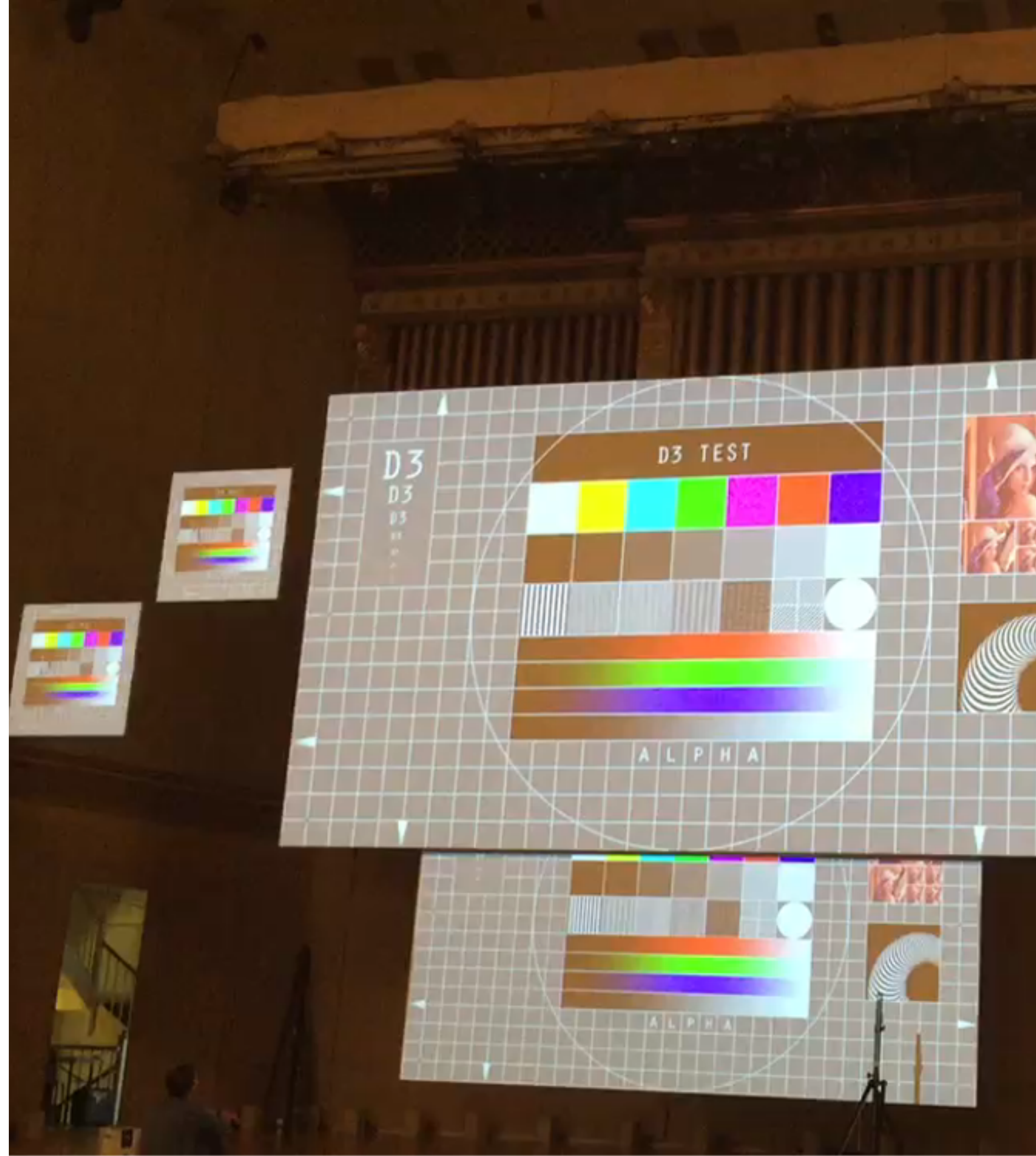

See the whole presentation

cci.fyi/value

Axis / Axes

Automation geeks always talk in terms of axes

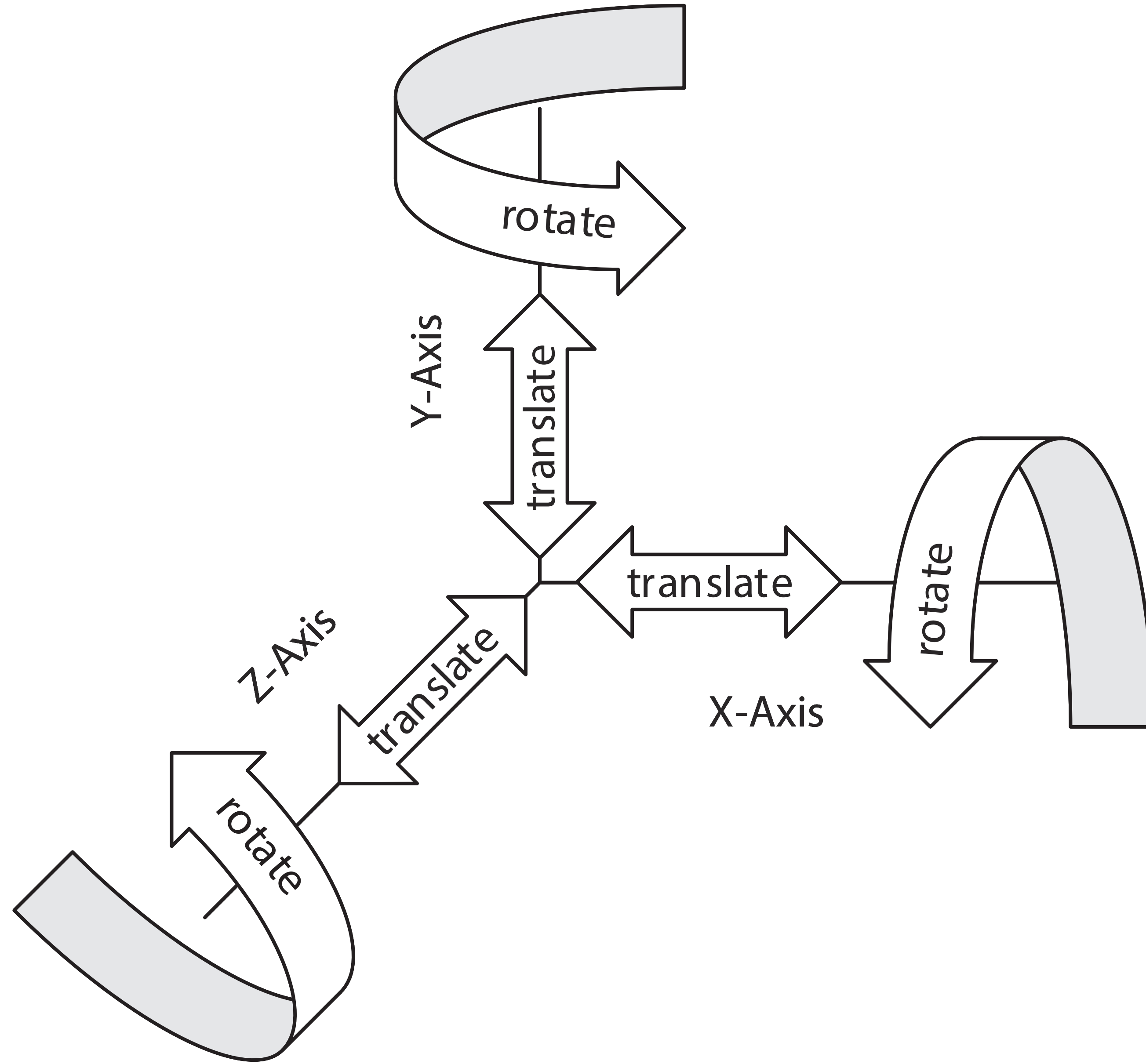



Welcome to the Machine(s)

elmurode *PINK FLOYD*

Machines

Just the basics...

Machine	Motion
Winch	Tracking
Hoist	Flying
Revolve	Turning
Lift	Raising



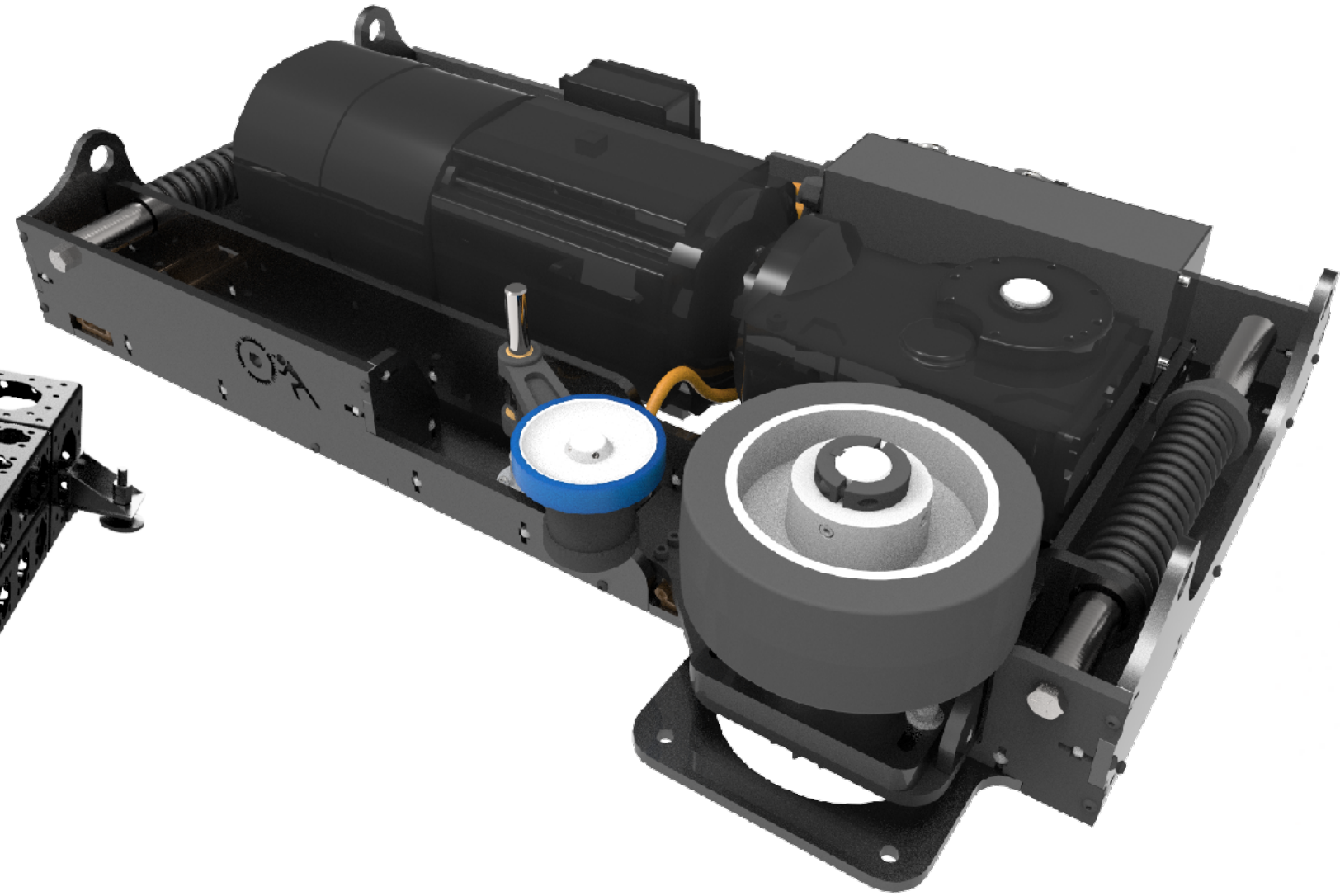

Pentagon of Power

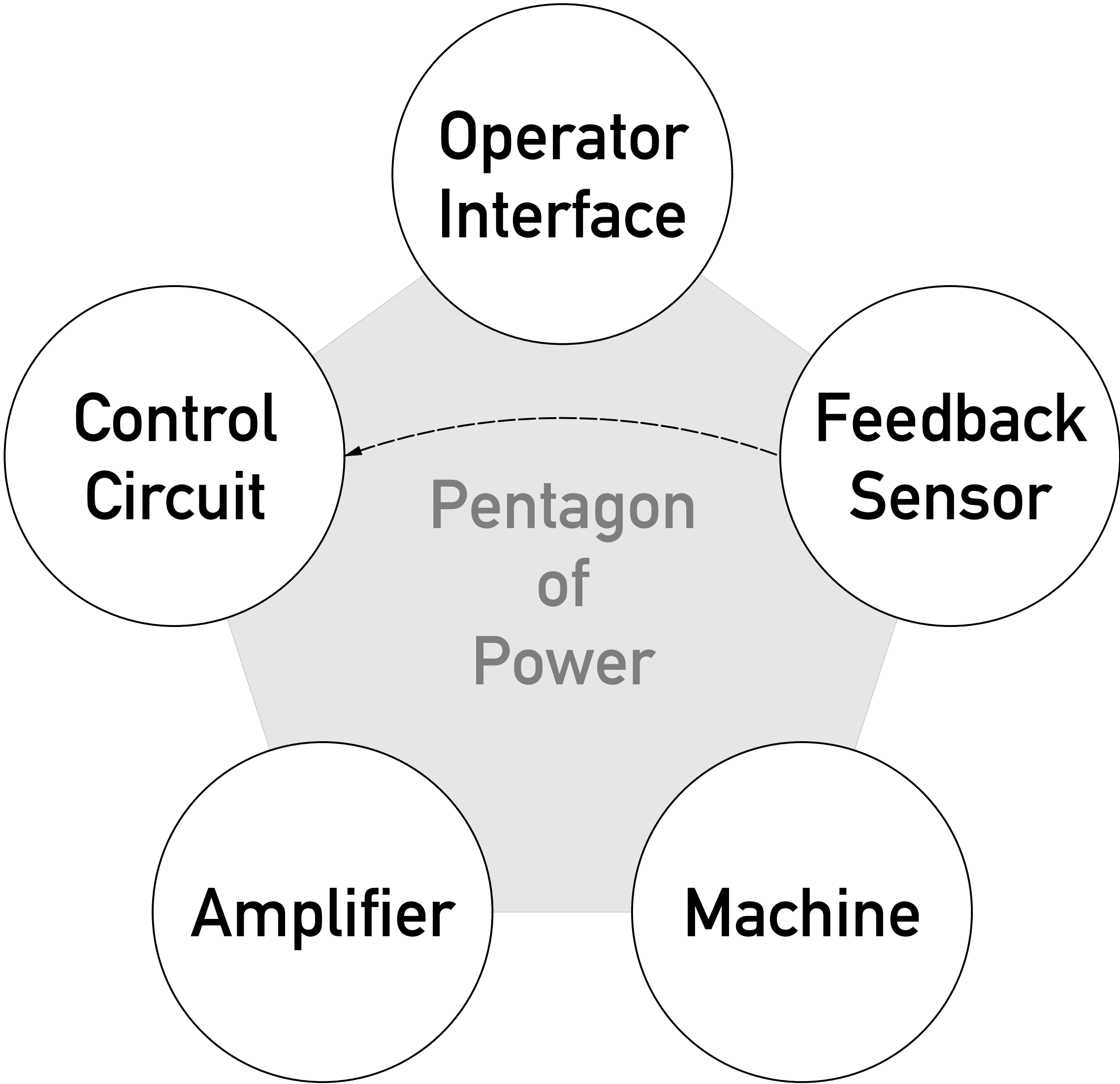

An iceberg floating in a blue ocean under a blue sky. The visible tip of the iceberg is small, while the much larger submerged part is visible below the water line. The text "Operator Interface" is overlaid in white on the submerged part of the iceberg.

Operator Interface

Operator Interface

Tell me what you need

- Database of Axes
- Manual moves
- Status reporting
- Cue writing and playback

GO Button Pressed

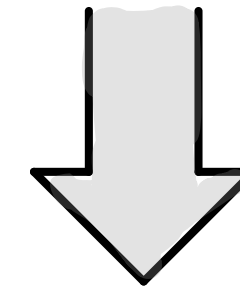

Start Downstage Traveler

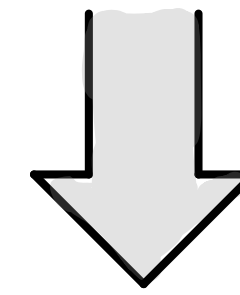

Wait 3 seconds

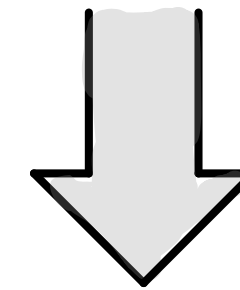

Start Upstage Traveler

Operator Interface

In

Out

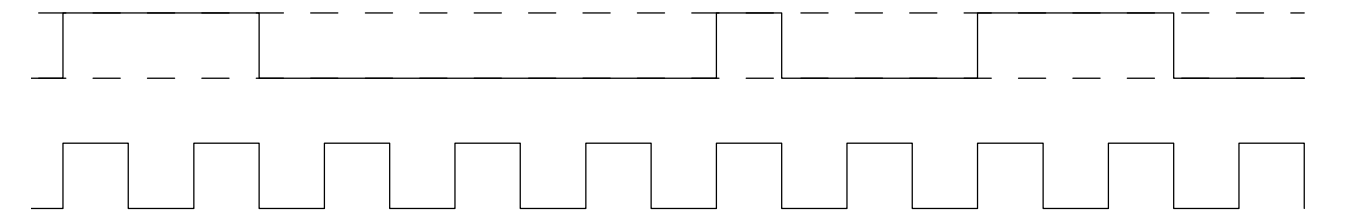
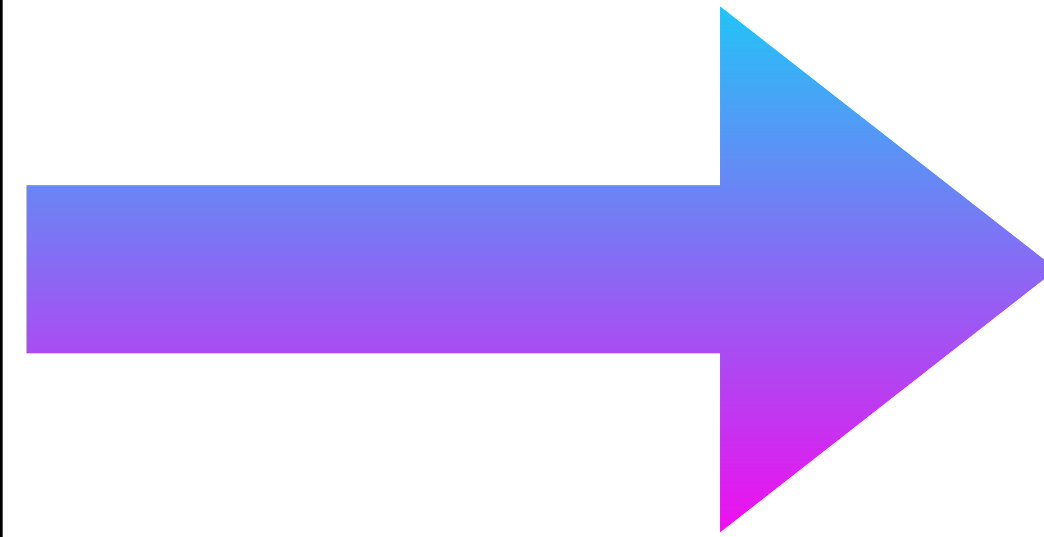
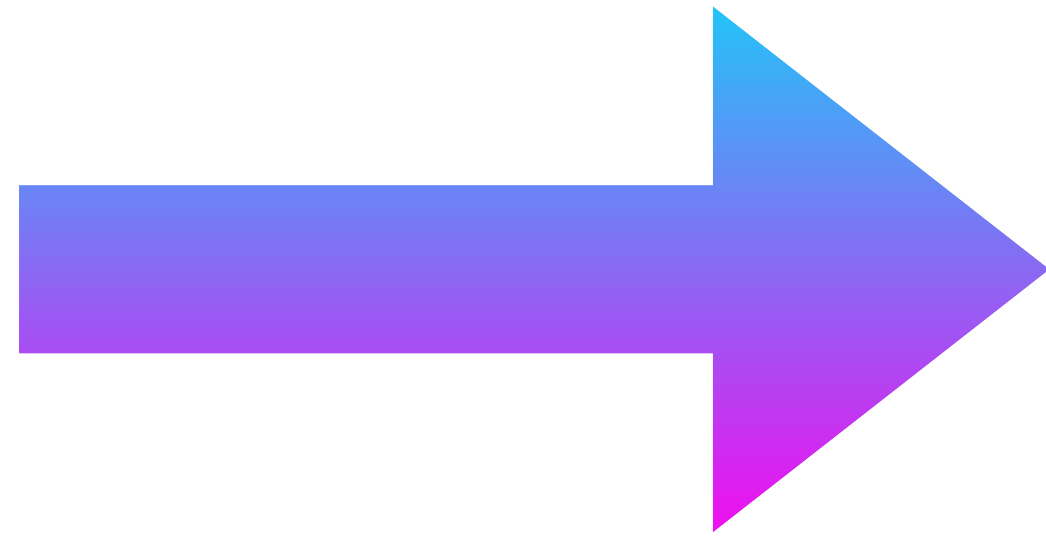

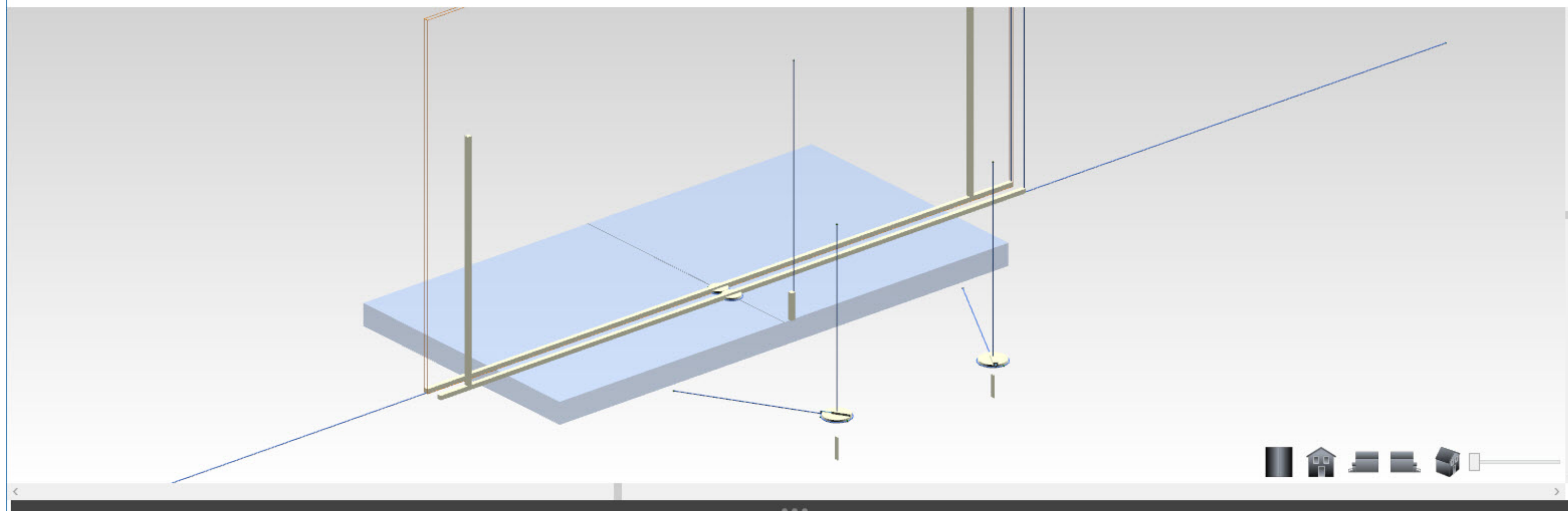

Control buttons for various axes:

- Disconnected
- US Lift (0')
- US Travel (0')
- US Spin (0')
- DS Lift (0')
- DS Travel (0')
- DS Spin (0')
- HL Lift (0')
- HL Travel (0')
- HL Spin (0')
- HR Lift (0')
- HR Travel (0')
- HR Spin (0')
- Center Winch (0')
- Stage 1 Axis (0')

Stagehand control grid with position and speed settings:

20'	21.0s	20'	21.0s	20'	21.0s	20'	21.0s
0°	0.0s	0°	0.0s	0°	0.0s	0°	0.0s
60.3'	61.3s	0°	0.0s	10'	7.0s	25'	26.0s
150°	25.0s	120°	22.0s	120°	22.0s	120°	22.0s
-150°	35.0s	-120°	35.0s	-120°	35.0s	-120°	35.0s
51'	29.0s	15'	47.3s	90°	34.0s	46'	22.0s
5'	41.0s	90°	31.0s	46'	22.0s	5'	41.0s
-90°	11.0s	45'	21.5s	0°	6.0s	52.4'	6.0s
94°	46.6s	0°	6.0s	44'	2.3s	-22.5°	15.5s
23.22'	15.5s	75°	16.5s	-22.5°	15.5s	31'	9.0s
19'	15.0s	19'	15.0s	19'	15.0s	11'	16.0s

Bottom left controls:

- link to 10
- cue 10.1 9.0s up +8'
- link to 10.1
- cue 10.2 16.0s down -10'
- 11' 16.0s
- 19' 15.0s
- 15' 15.0s

Enable All Links



US Lift

Position 0'

Manual Controls

Reverse Forward

Slider control

Network

Network Connected

IP Address 192.168.10.41

Auto-repair

Connect Disconnect

Hardware Info

Stagehand 1.7

Firmware Installed v2147483647

Most Recent Firmware v15

Update Motor Firmware

Position

Reset Position

Must be between 0.00 and 84,367.40

Max Forward Position 80

Min Reverse Position 0

Position Scale 12726.976

Position Units feet

Max Position Error 0.2

Abort On Position Error

Position Error Loaded False

Speed

Speed 0/sec

Max Speed 5

Default Speed 2.5

Default Accel 0.5

Tuning

Proportional Gain 2

Derivative Gain 0

Derivative Sampling 0

Cue #

Play Stop

Navigation buttons

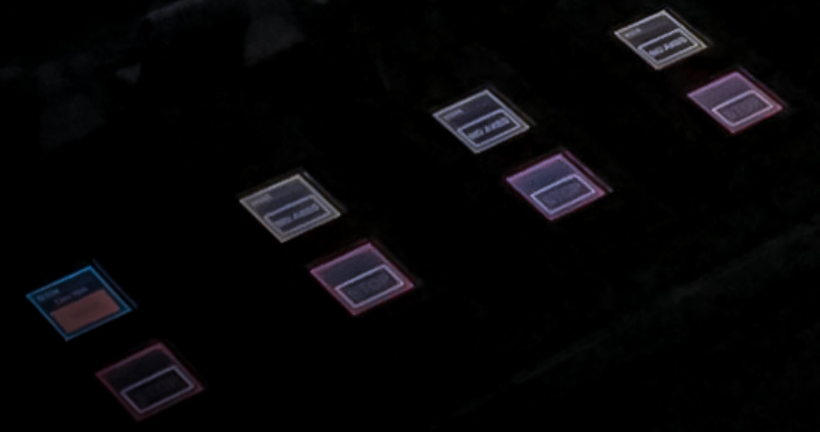
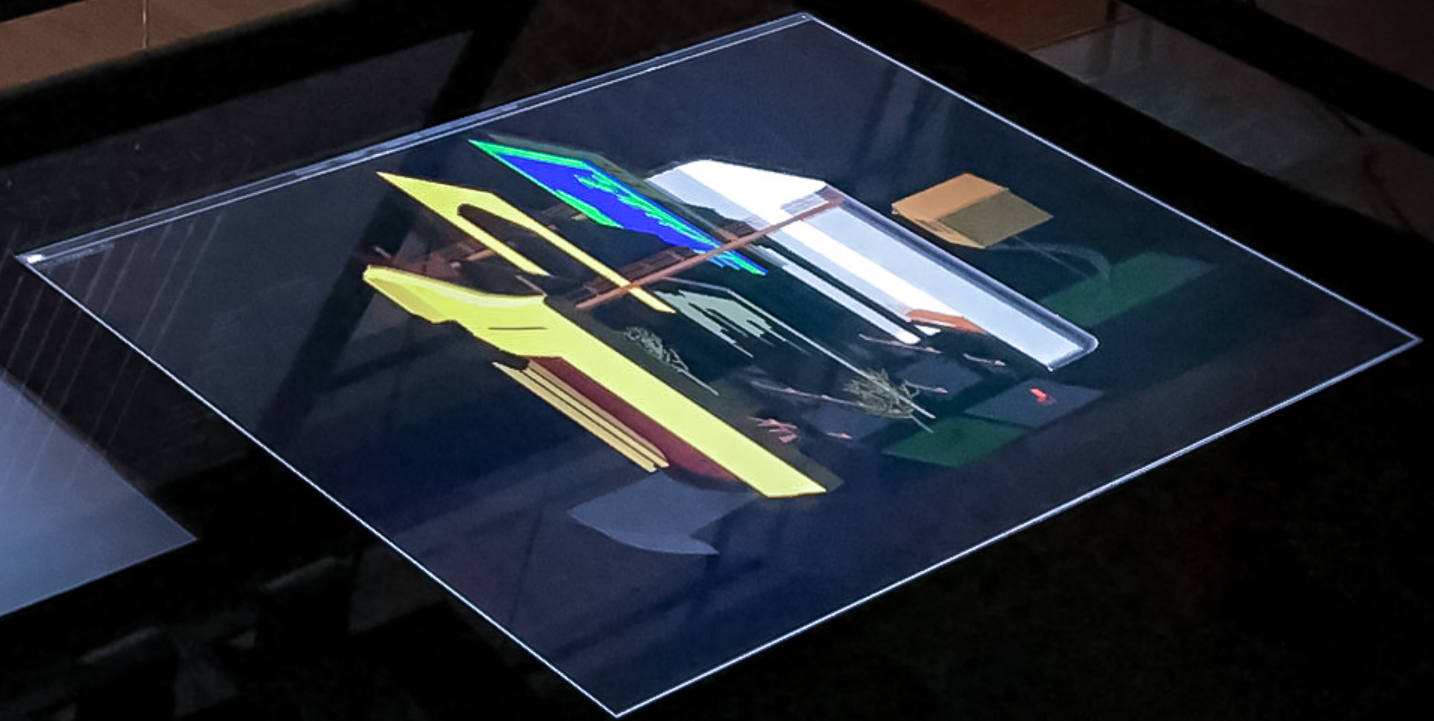
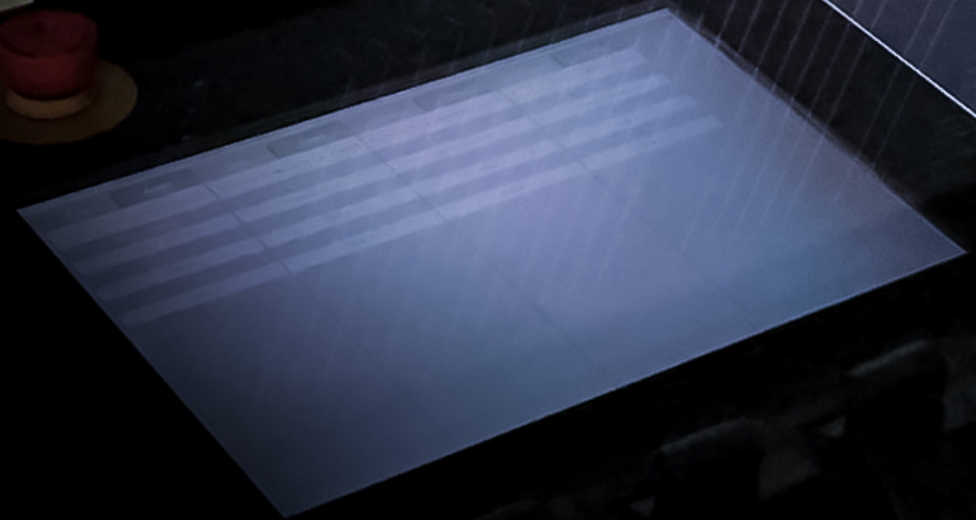

TAIT

Motion Controller



Motion Control

Plot the course, stay on track

- Network interface
- Translate motion plan (trajectory)
- Convert trajectory into electrical command signal
- Self-adjusting based on feedback sensors

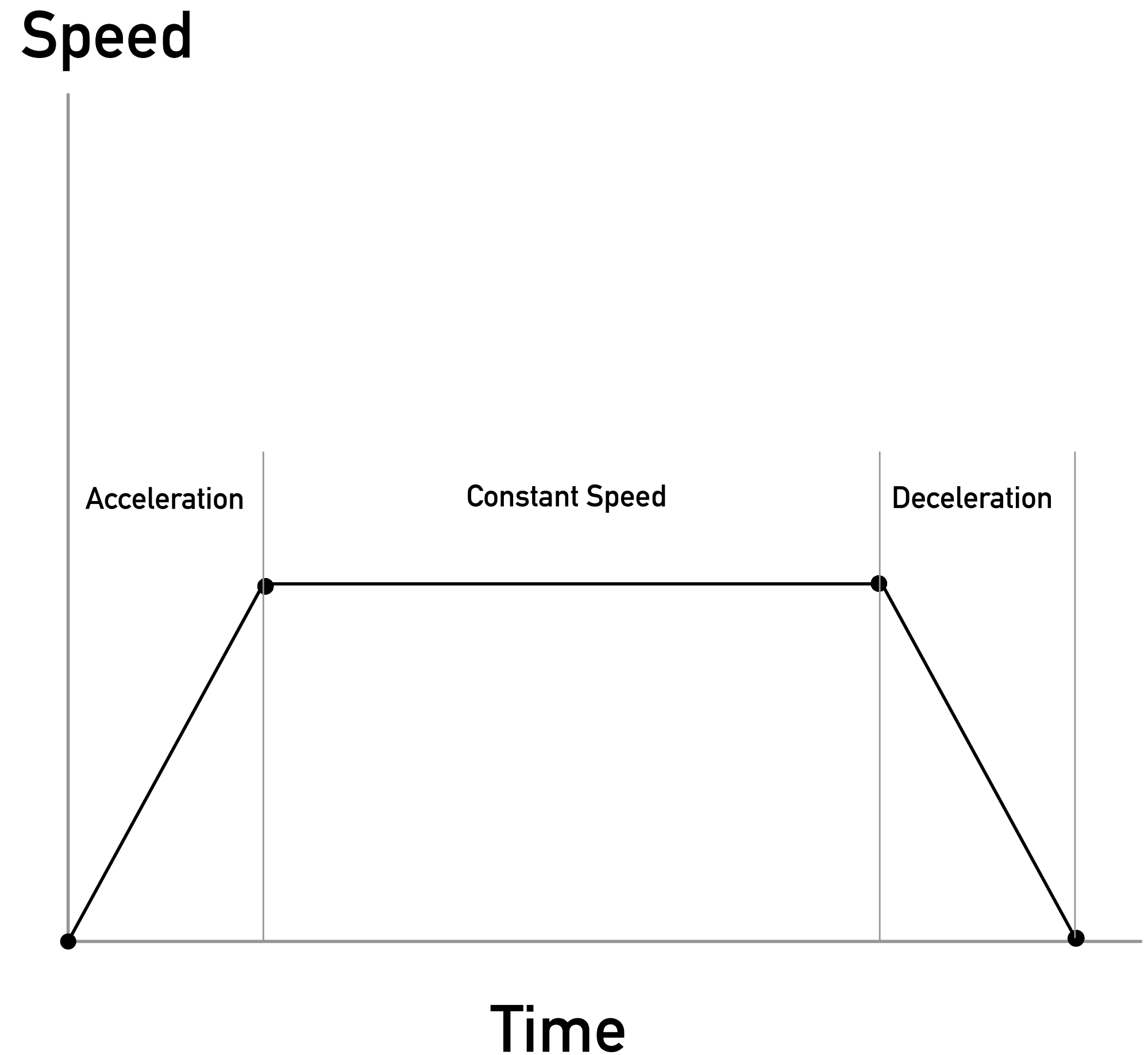

Motion Controller

In

Out

From Operator Interface

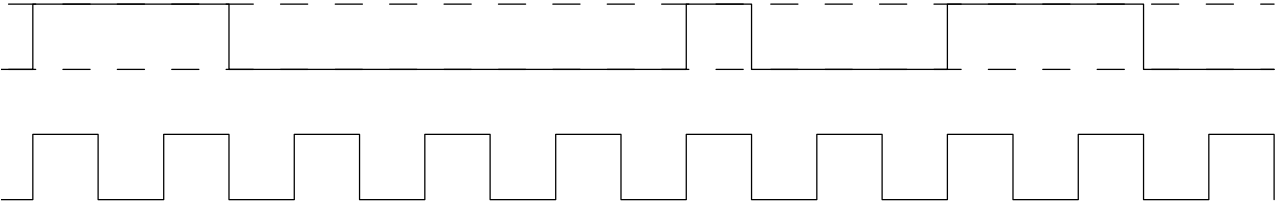

From Feedback Sensor

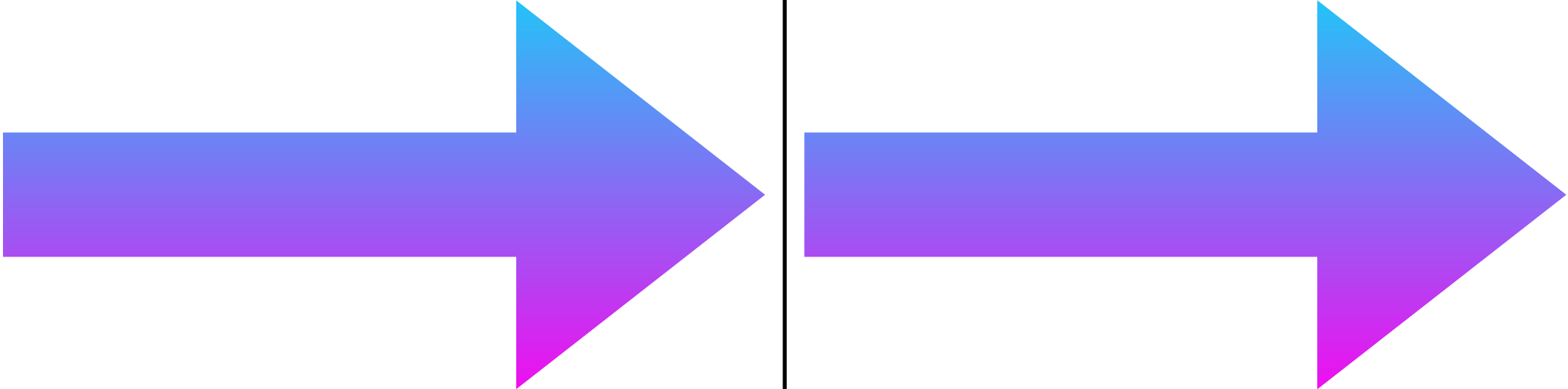
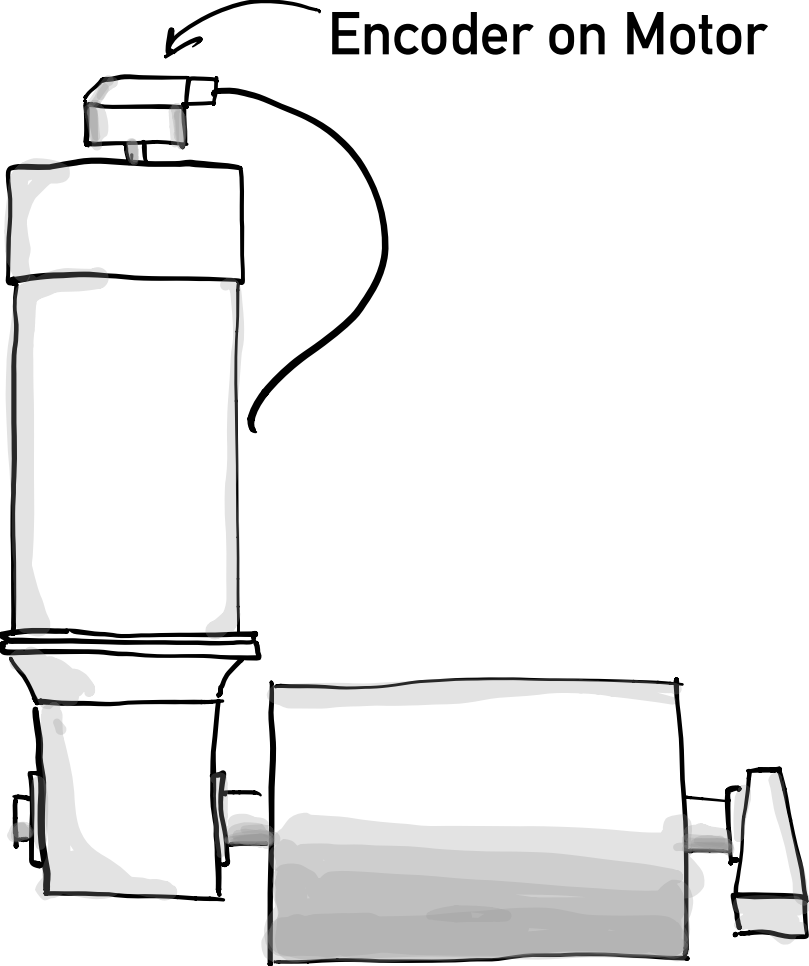

CONTROL

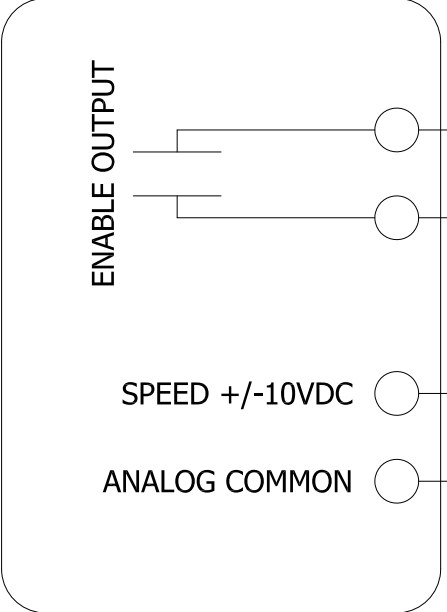

DRIVE

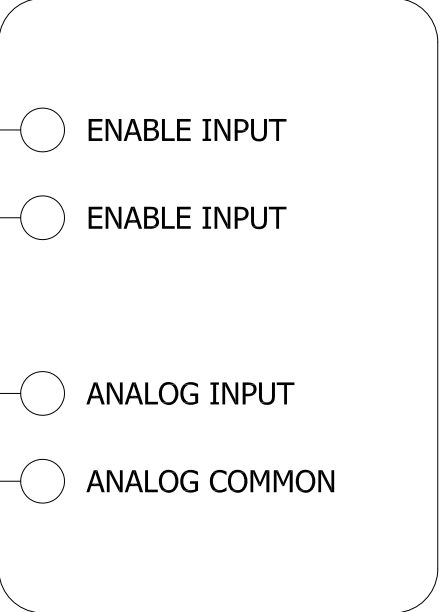

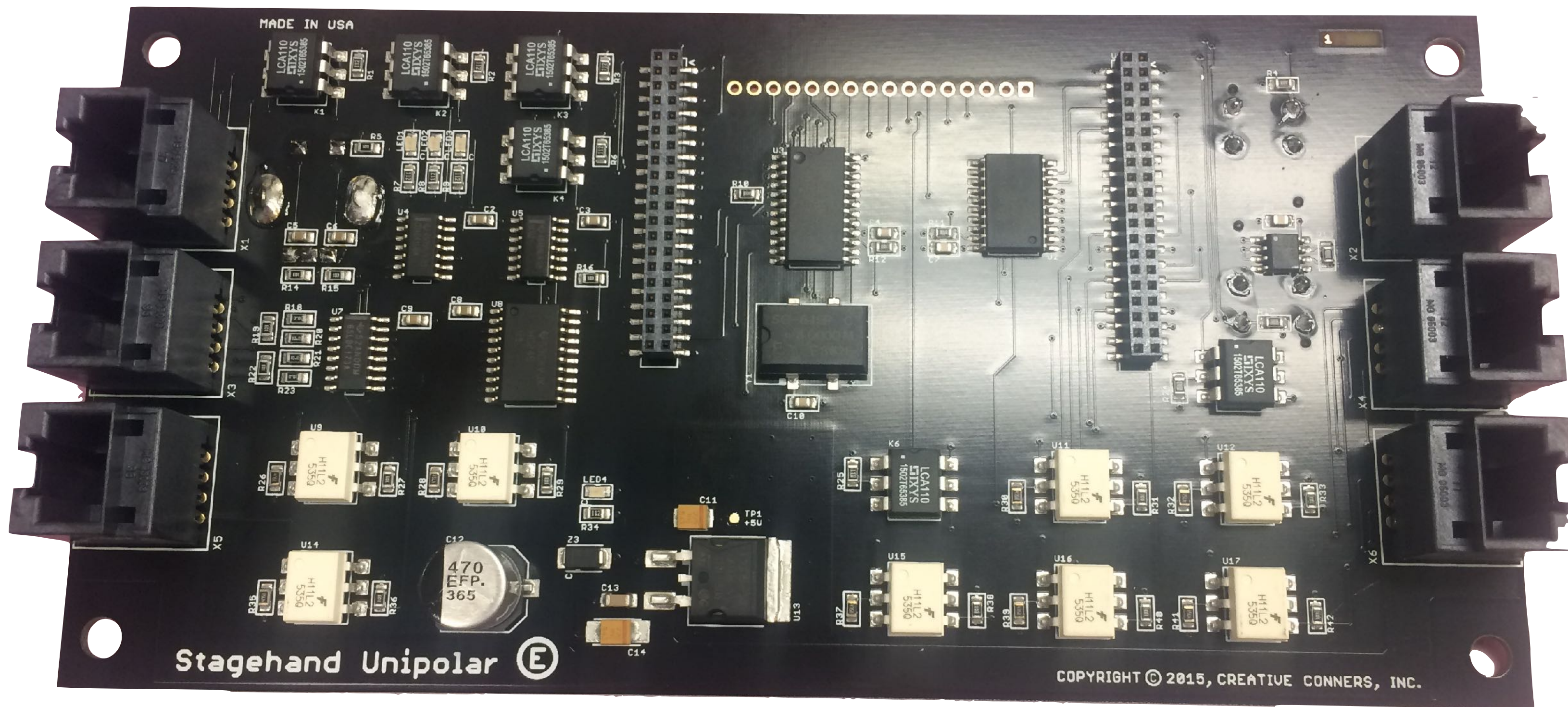

MADE IN USA

Stagehand Unipolar [®]

COPYRIGHT © 2015, CREATIVE CONNERS, INC.



Amplifier / Drive



Amplifier / Drive

Translation please

- Converts small signal to big power
- Matched to the needs of the motor / actuator

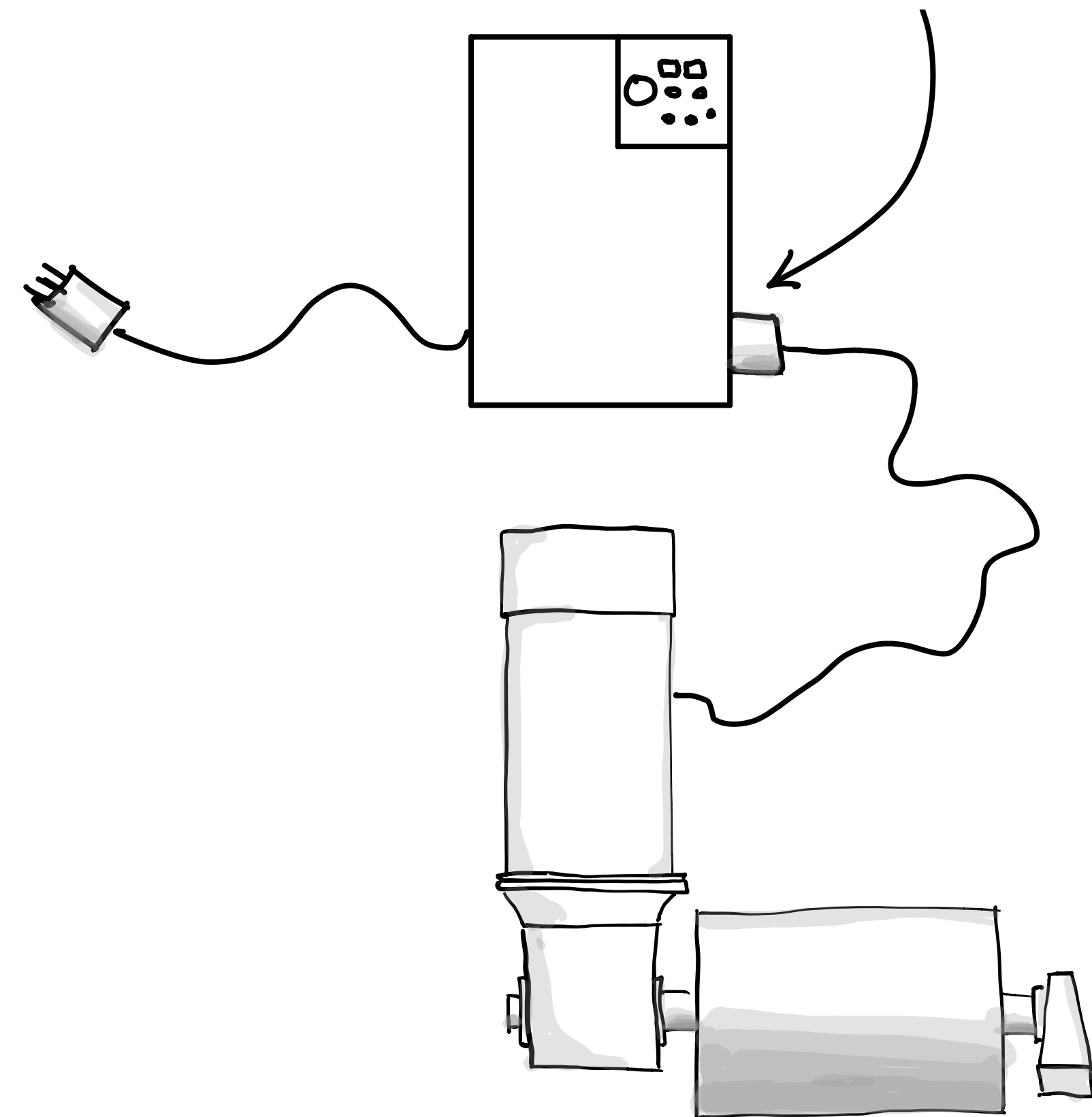

Amplifier / Drive

In

Out

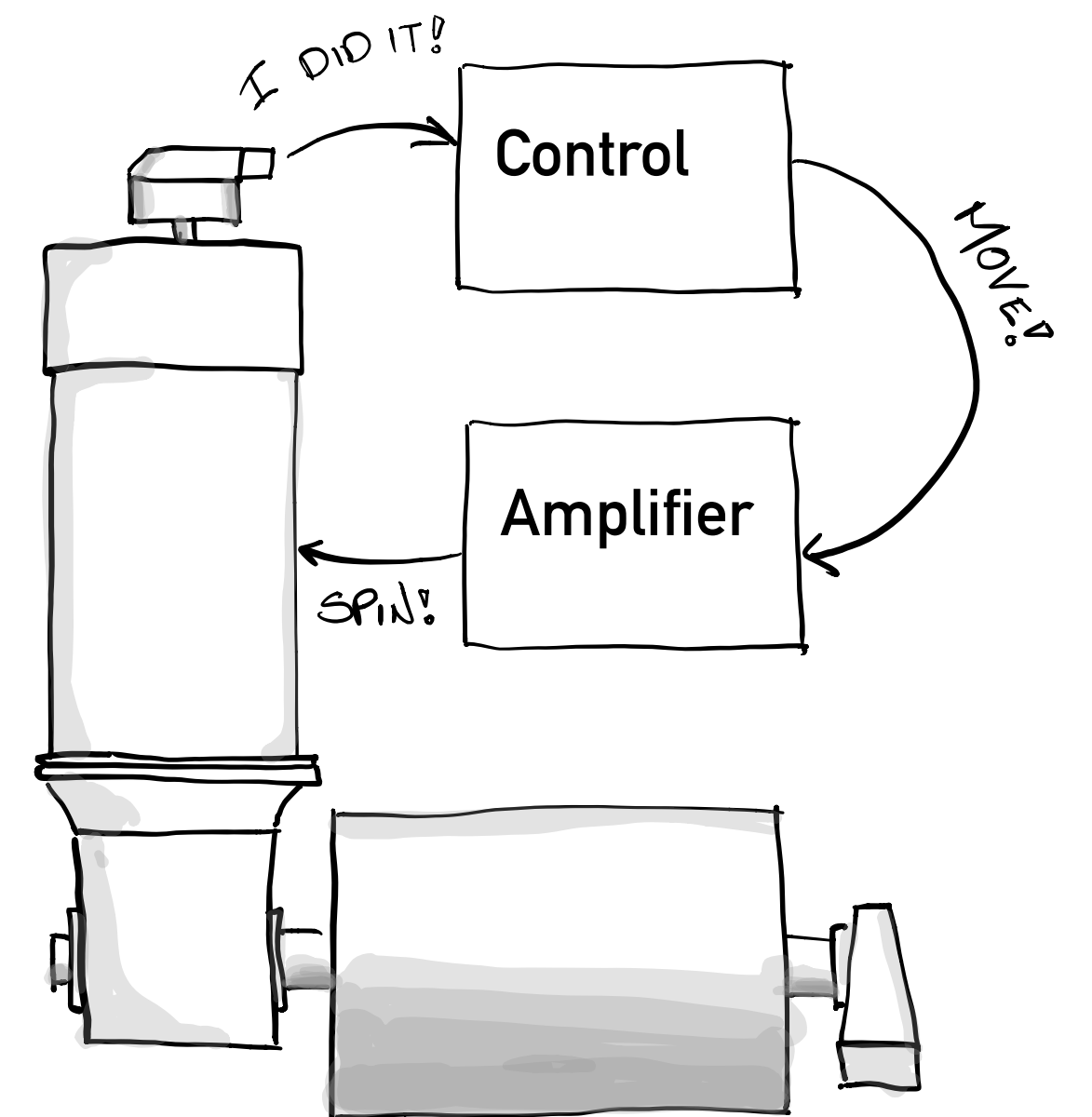
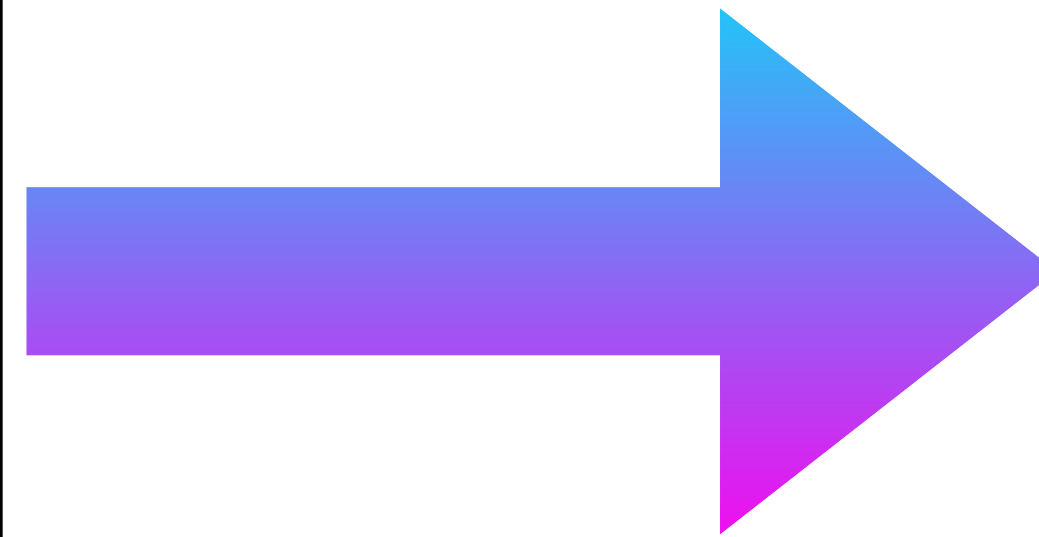
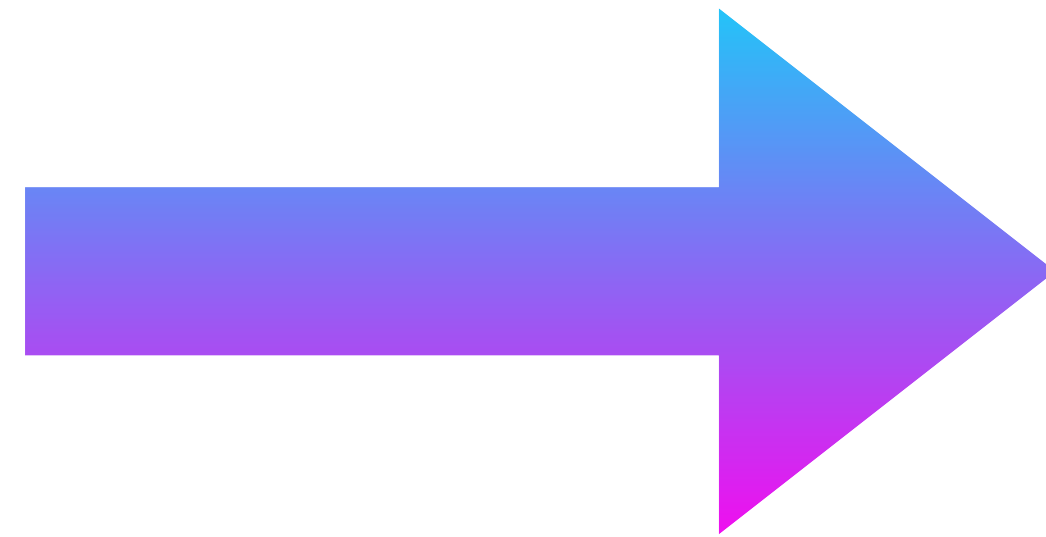
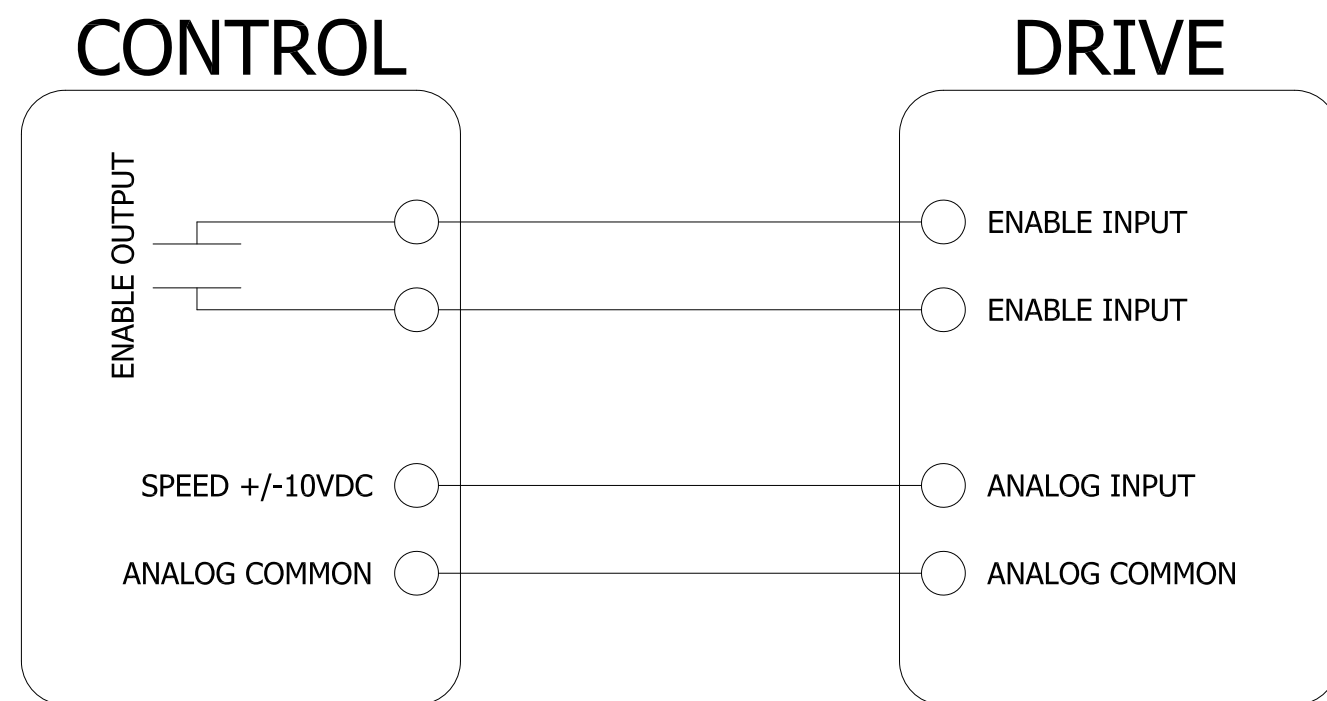

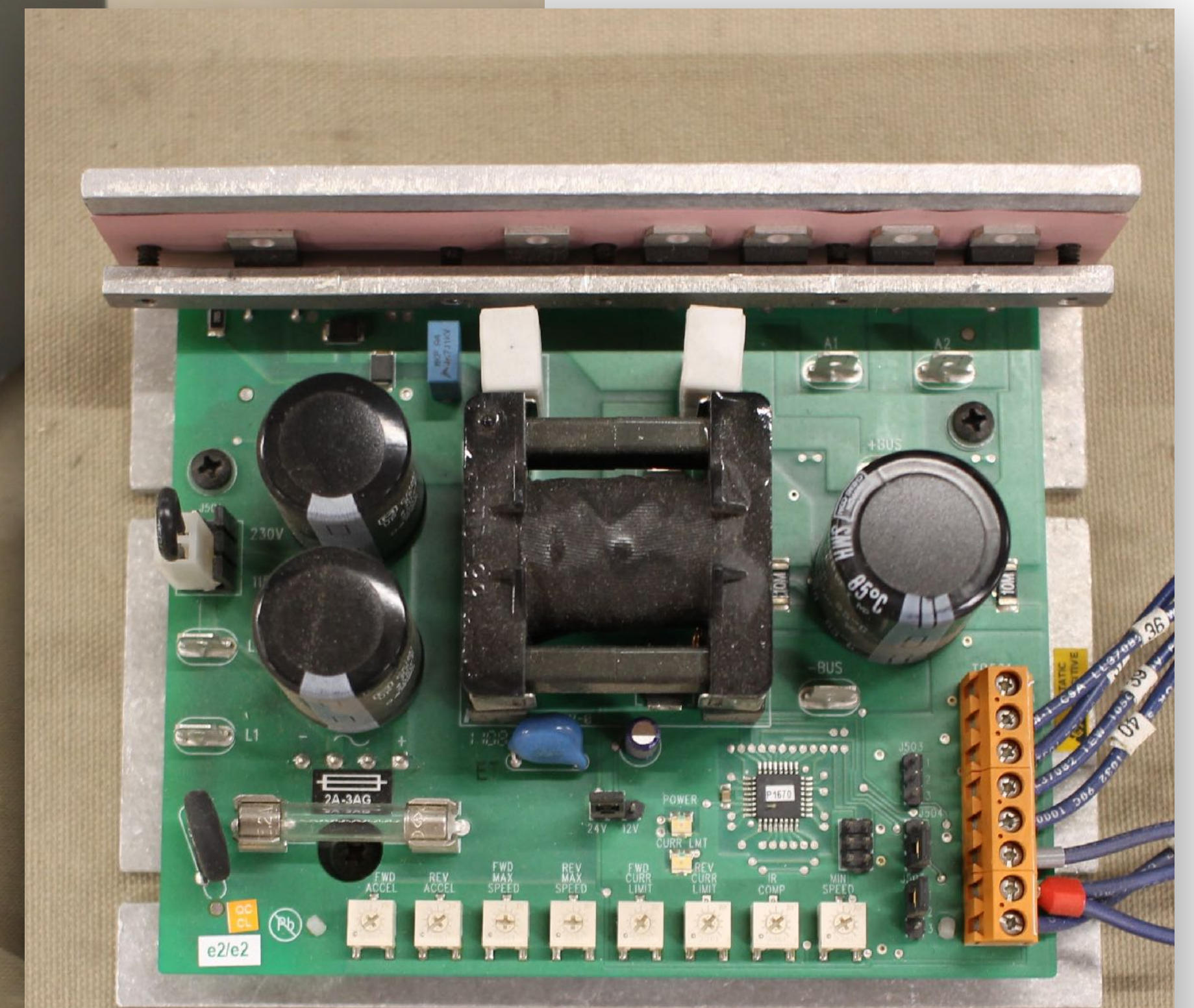
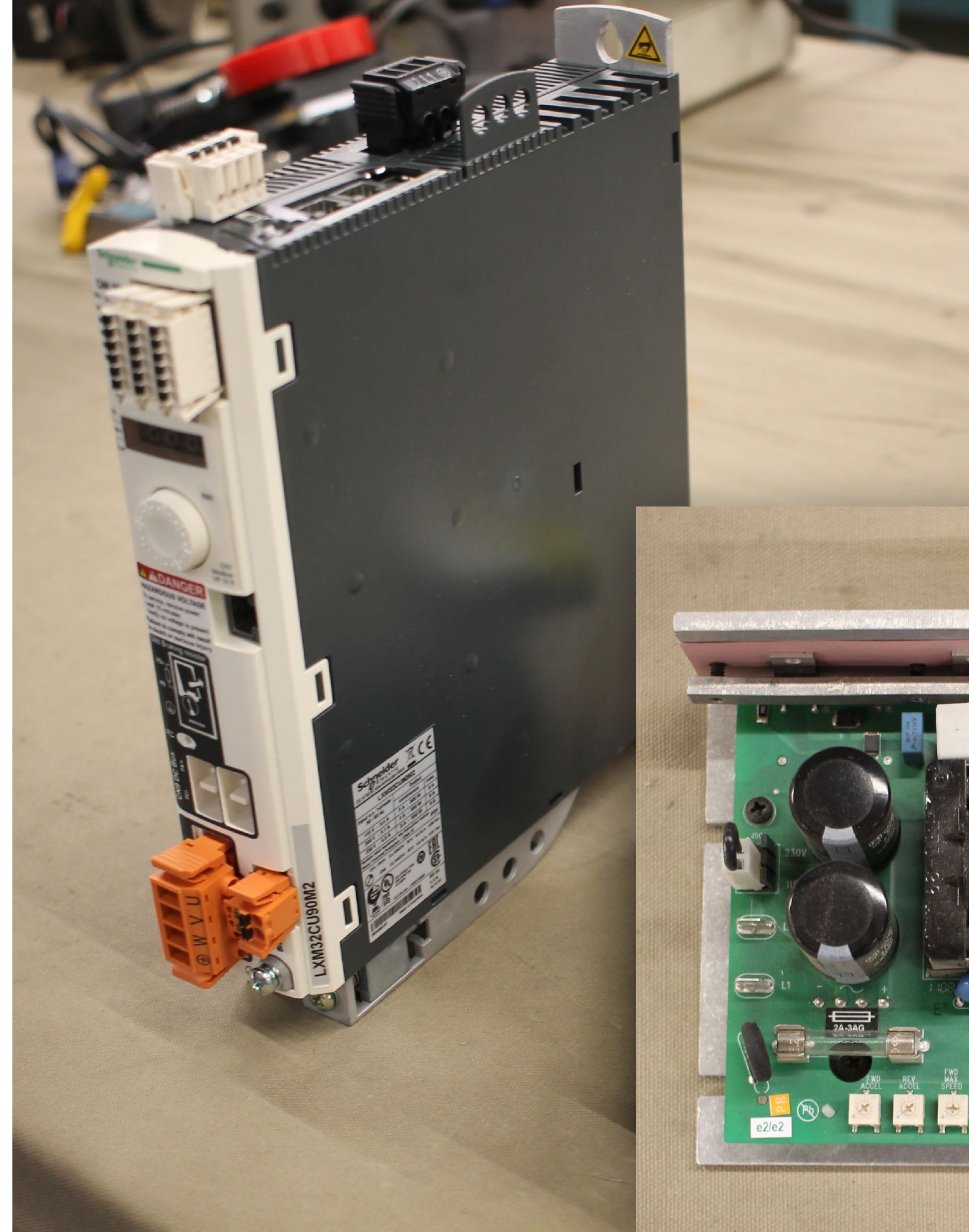



Machine

Machine

Make it happen

- Converts electrical energy in to physical movement

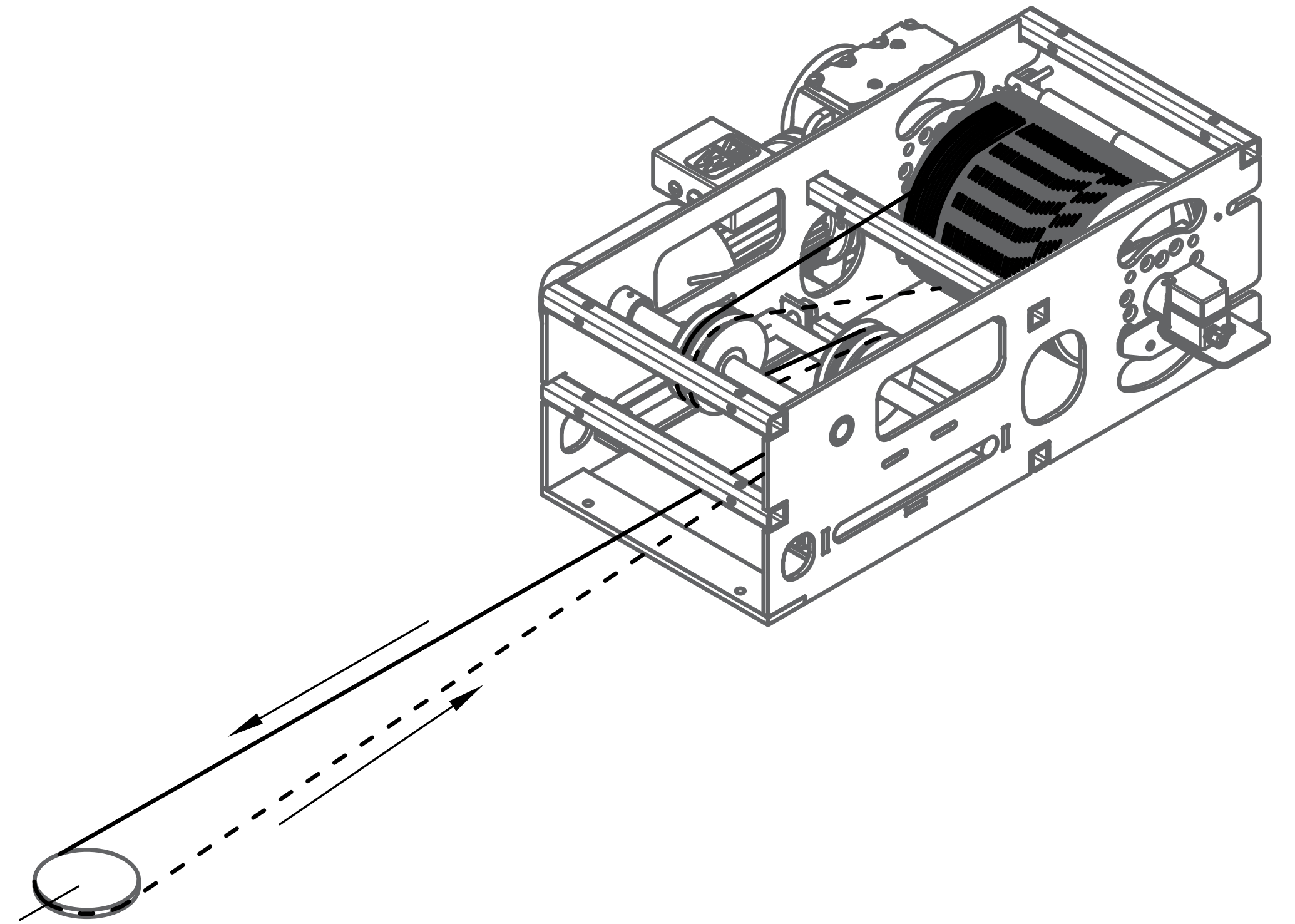

Machine

In

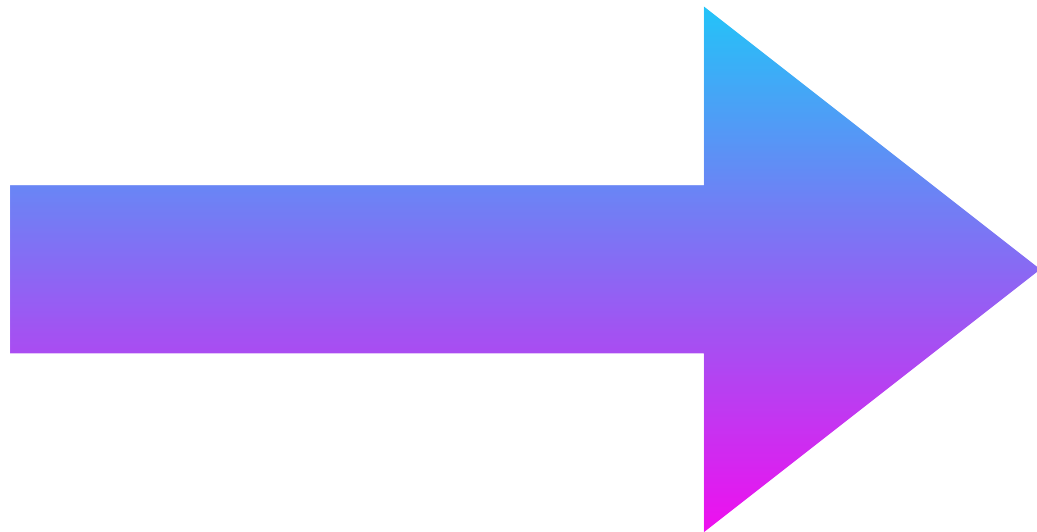
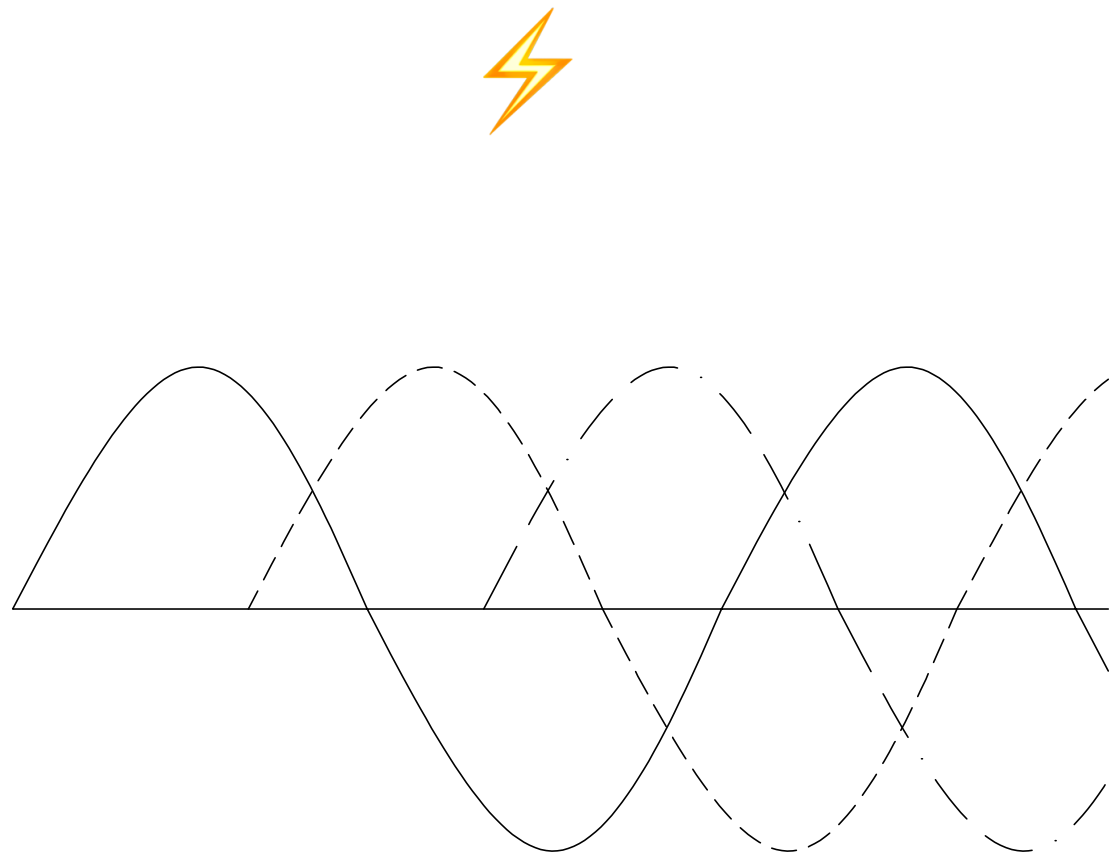

Out

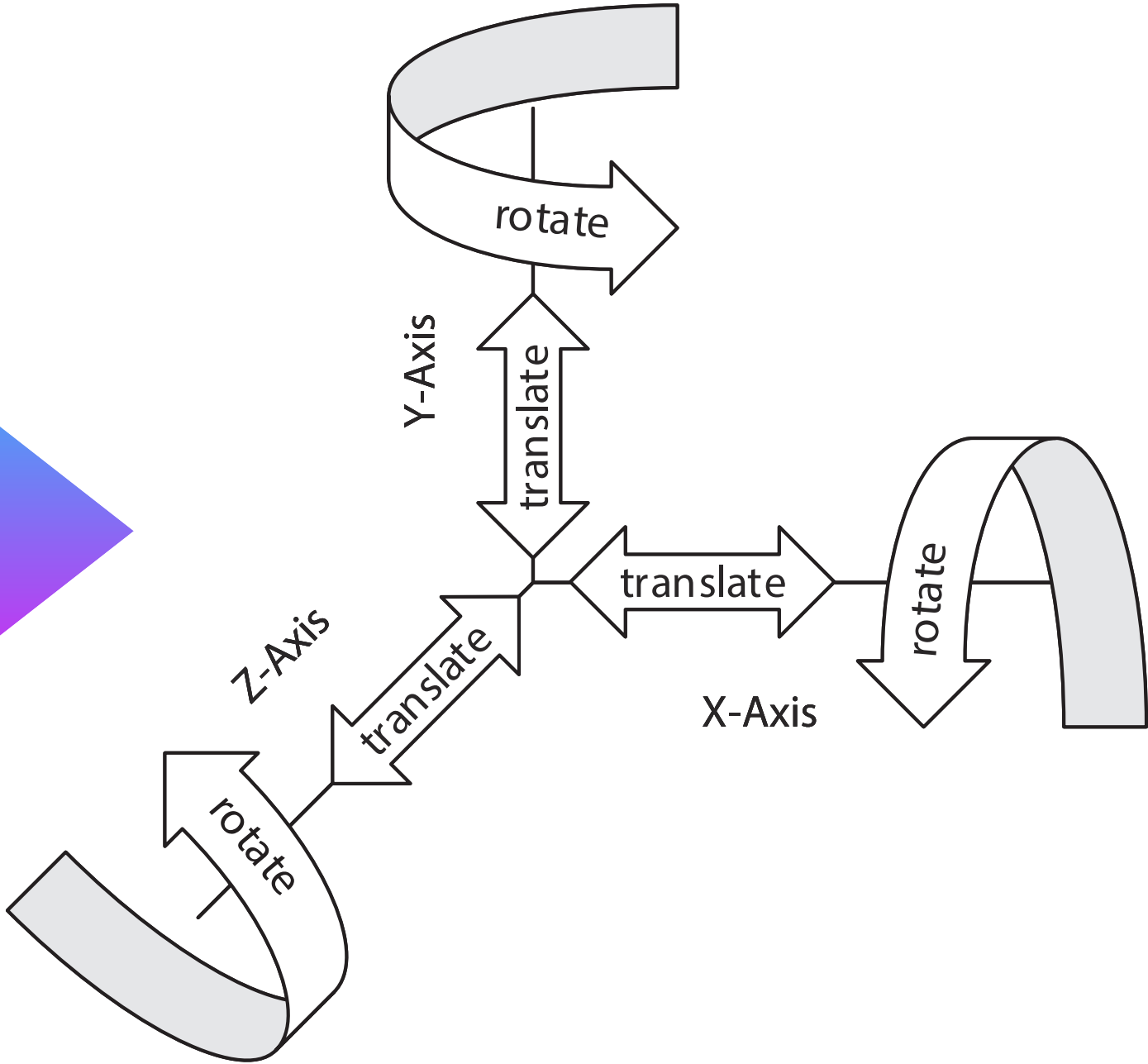

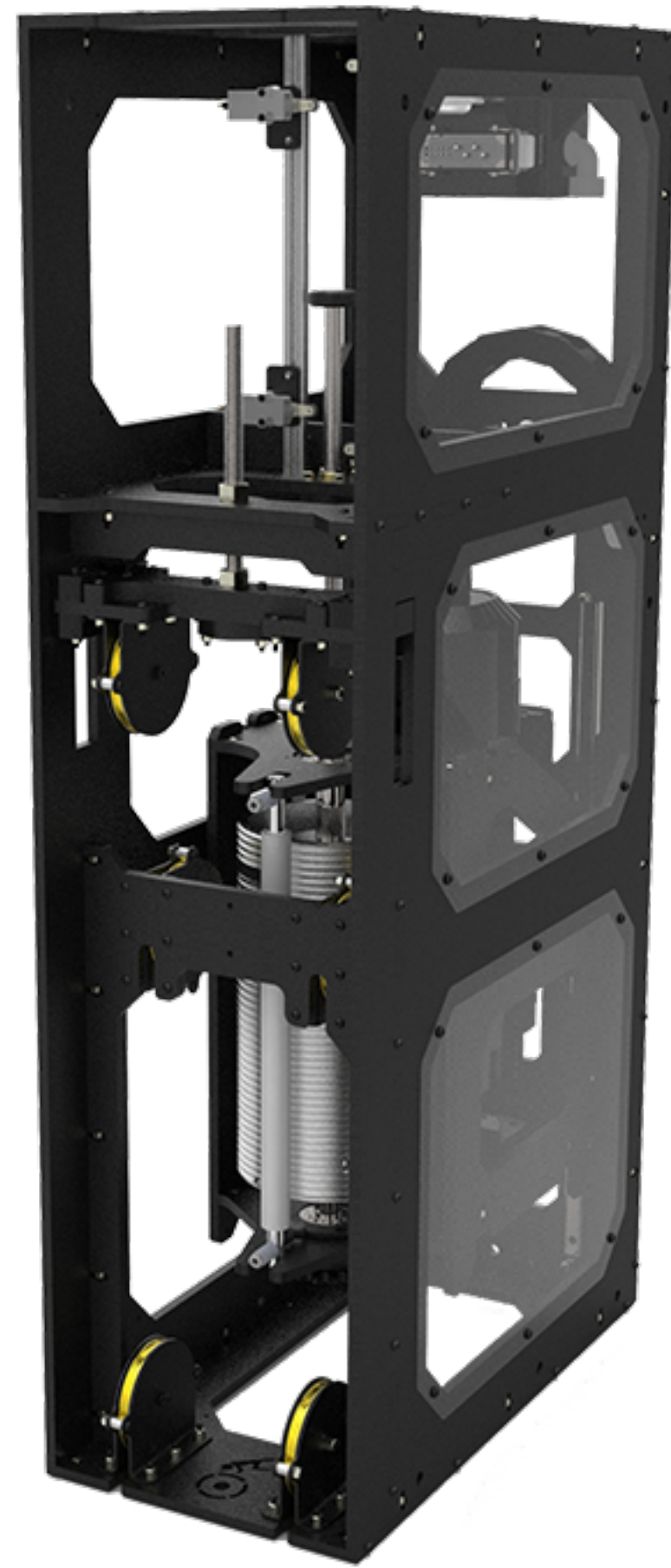

A yellow robotic arm is the central focus, extending from the left side of the frame. The background is a blurred industrial environment with blue and teal lighting. Overlaid on the scene is a network of white lines connecting various circular icons. These icons include a factory with a crane, a lightbulb with a dollar sign, a factory with smoke, a leaf with a plug, a gear with a person, and a stylized 'AI' logo. The overall aesthetic is high-tech and futuristic.

Feedback Sensors

Feedback Sensors

What's going on?

- Converts physical movement into electrical signal

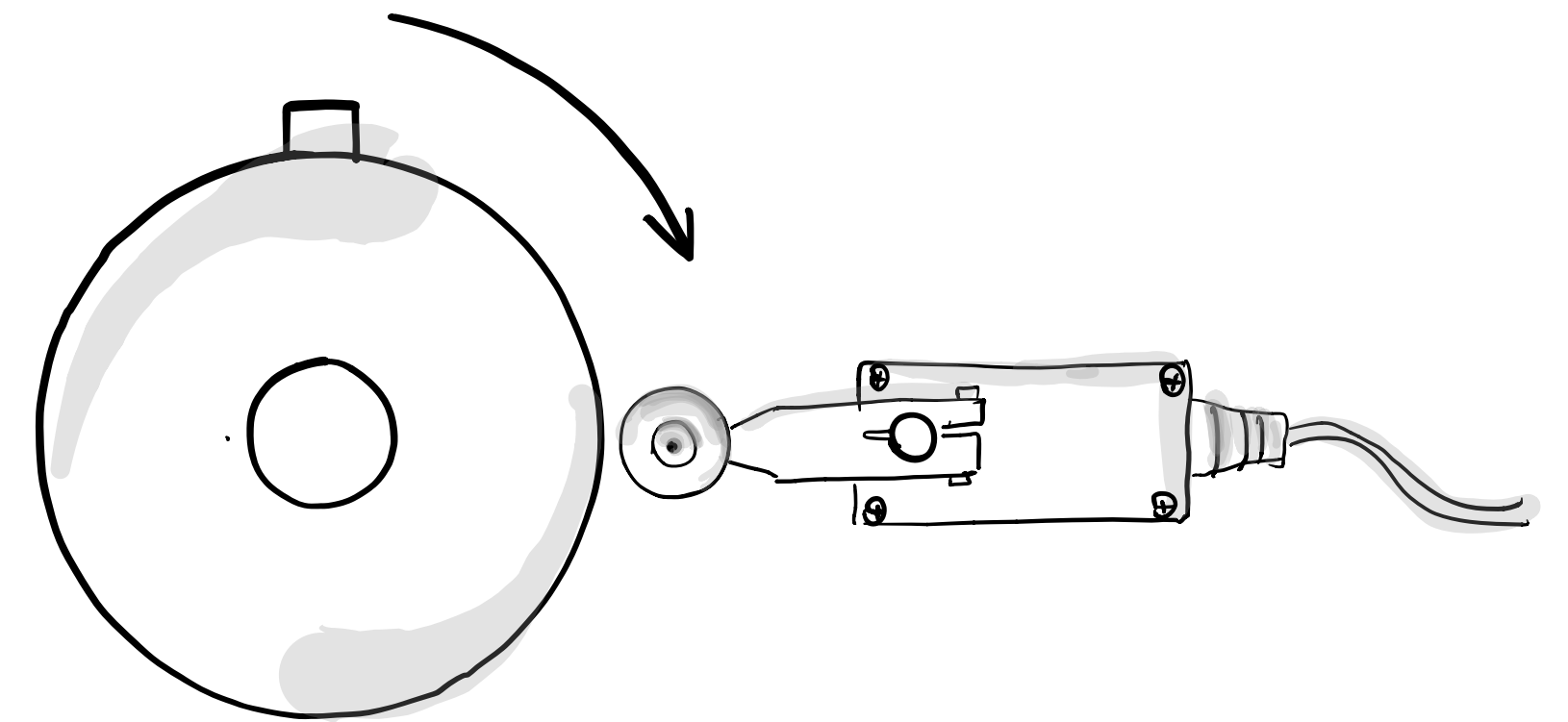

Slow Rotation



Fast Rotation

Feedback Sensors

In

Out

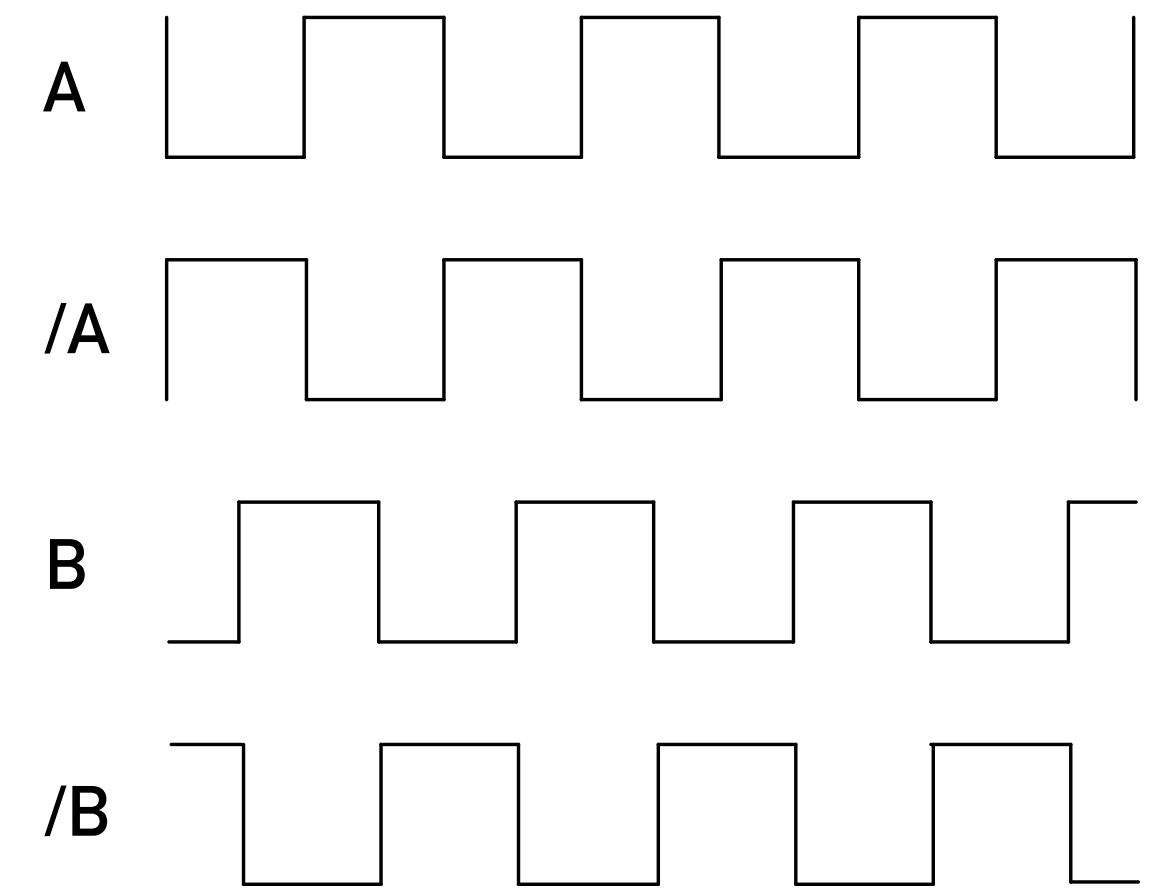
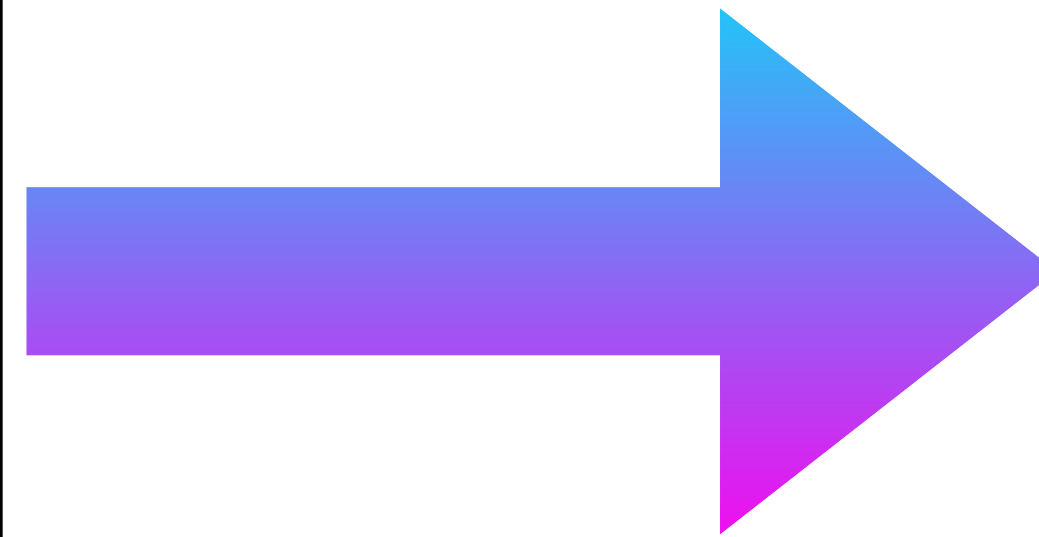
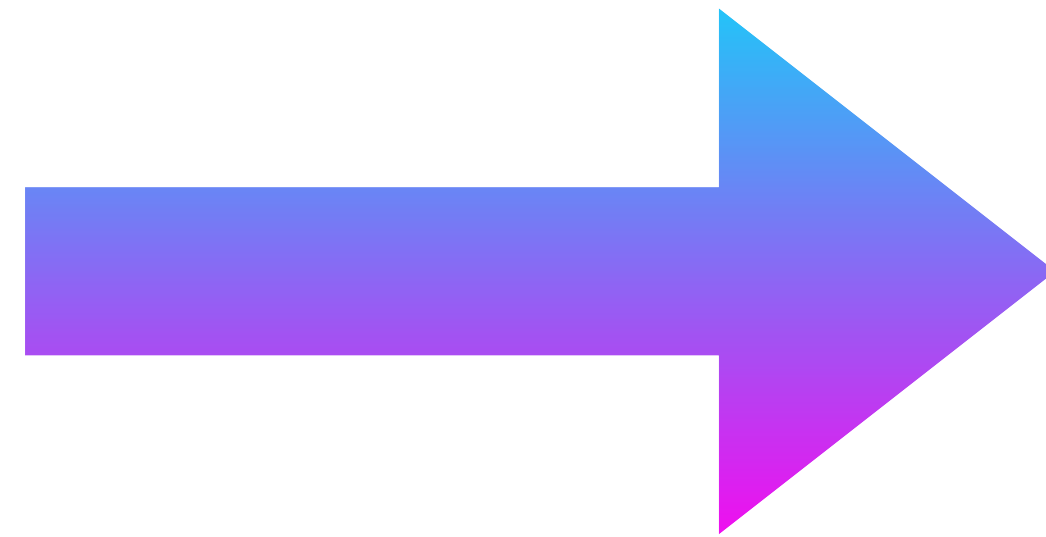
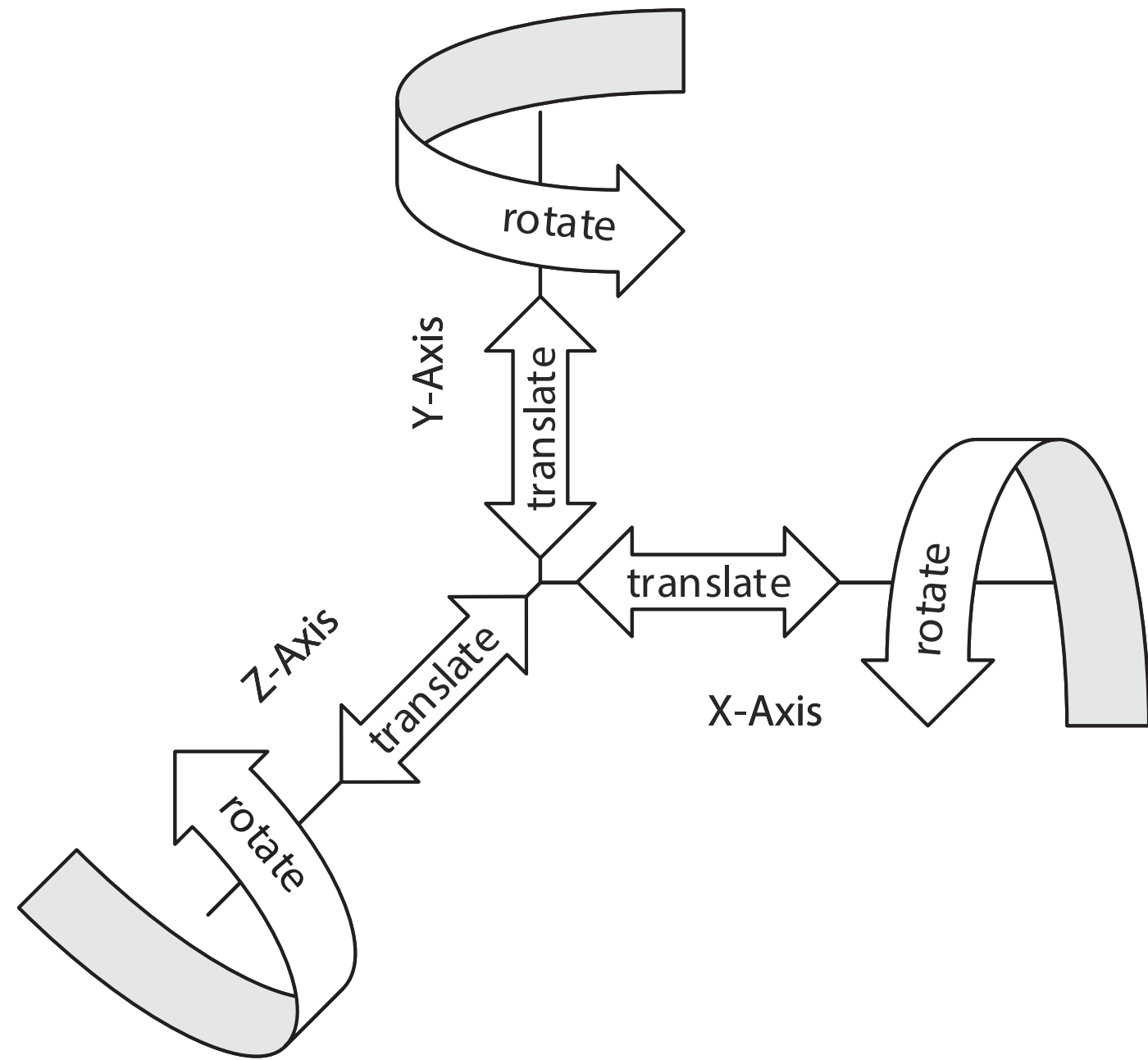

Feedback Sensors

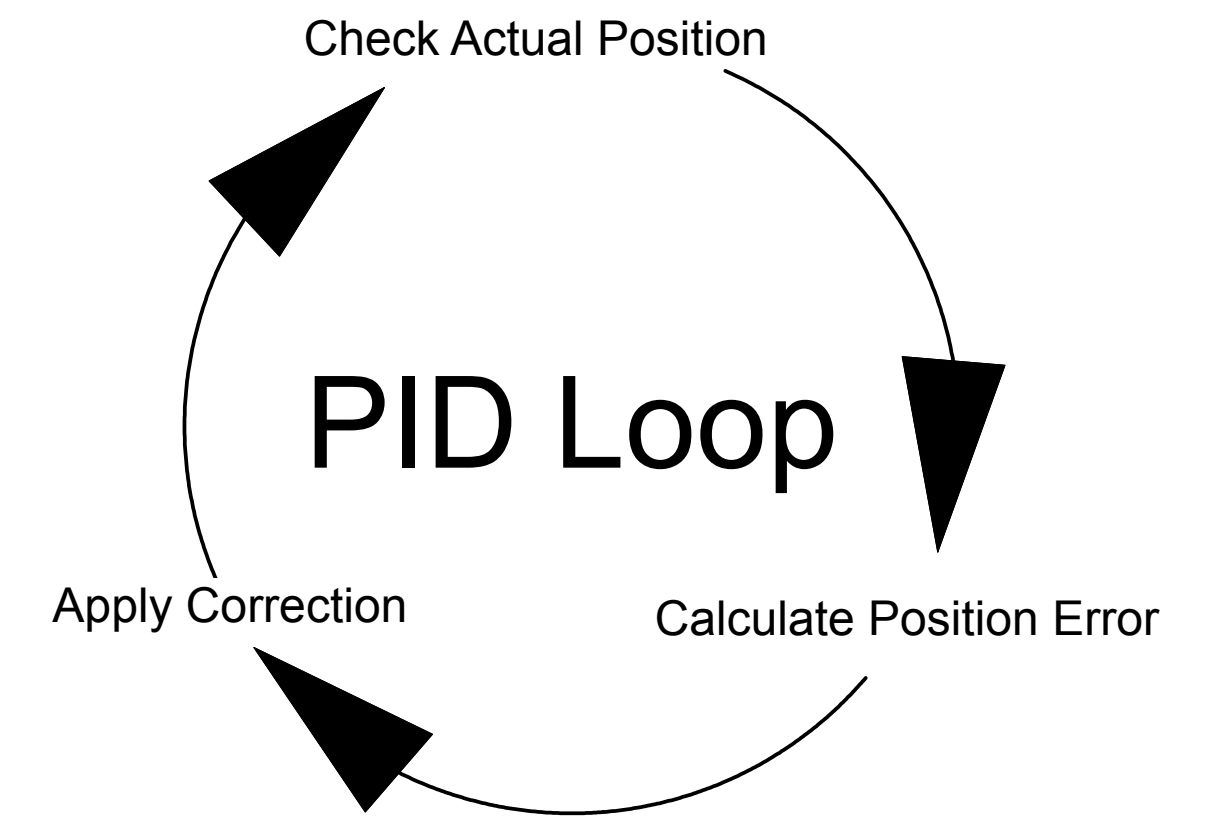
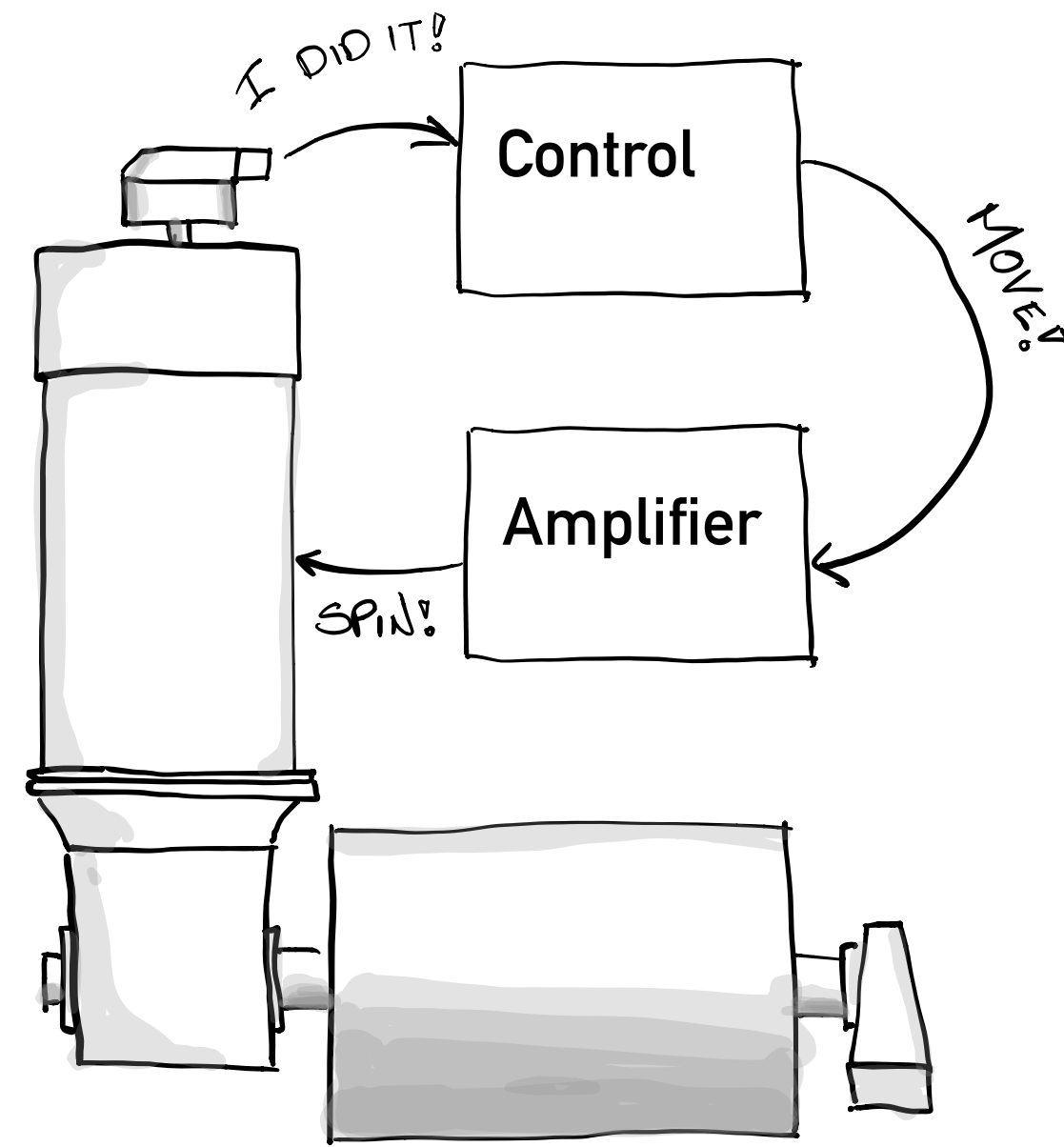
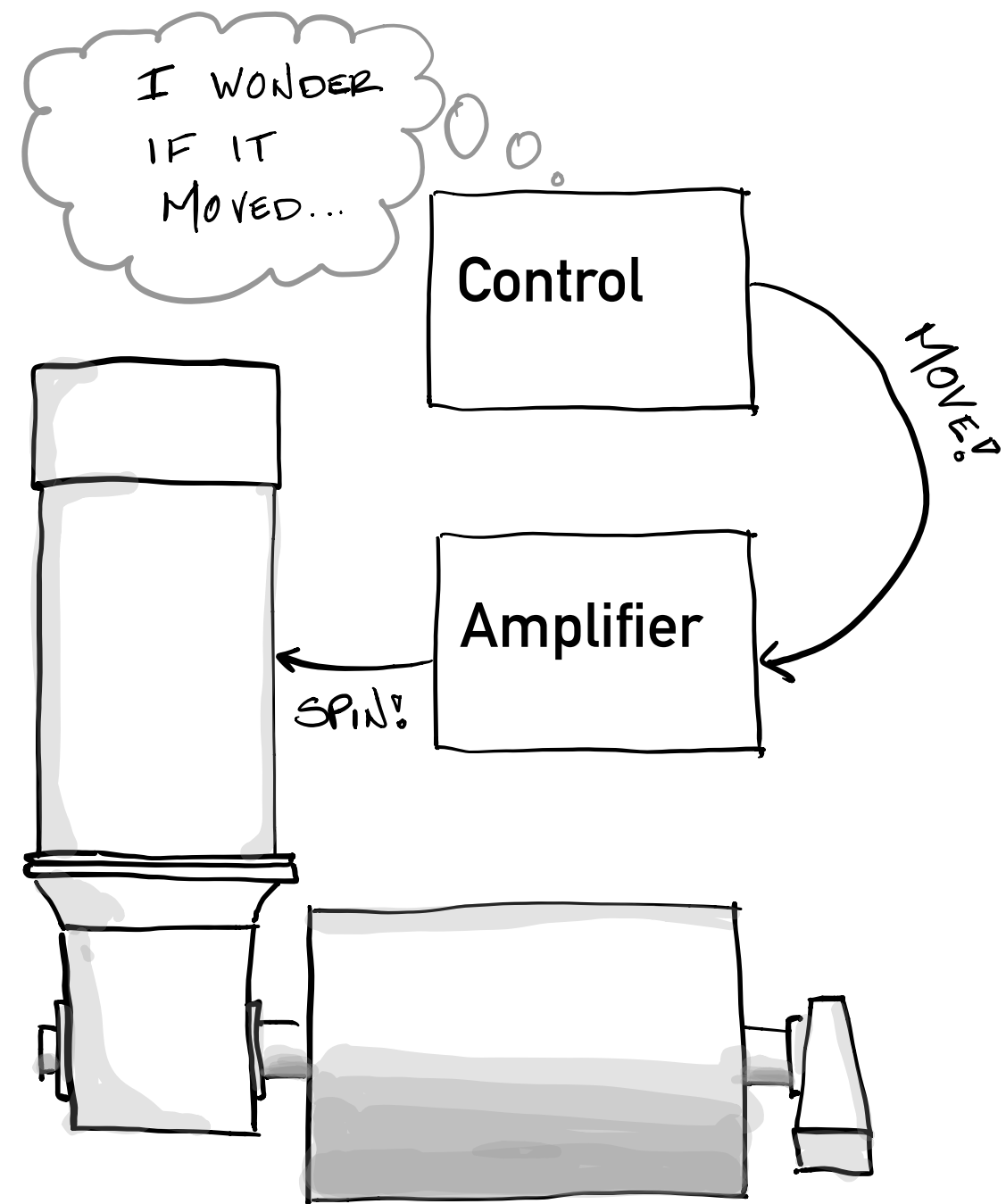



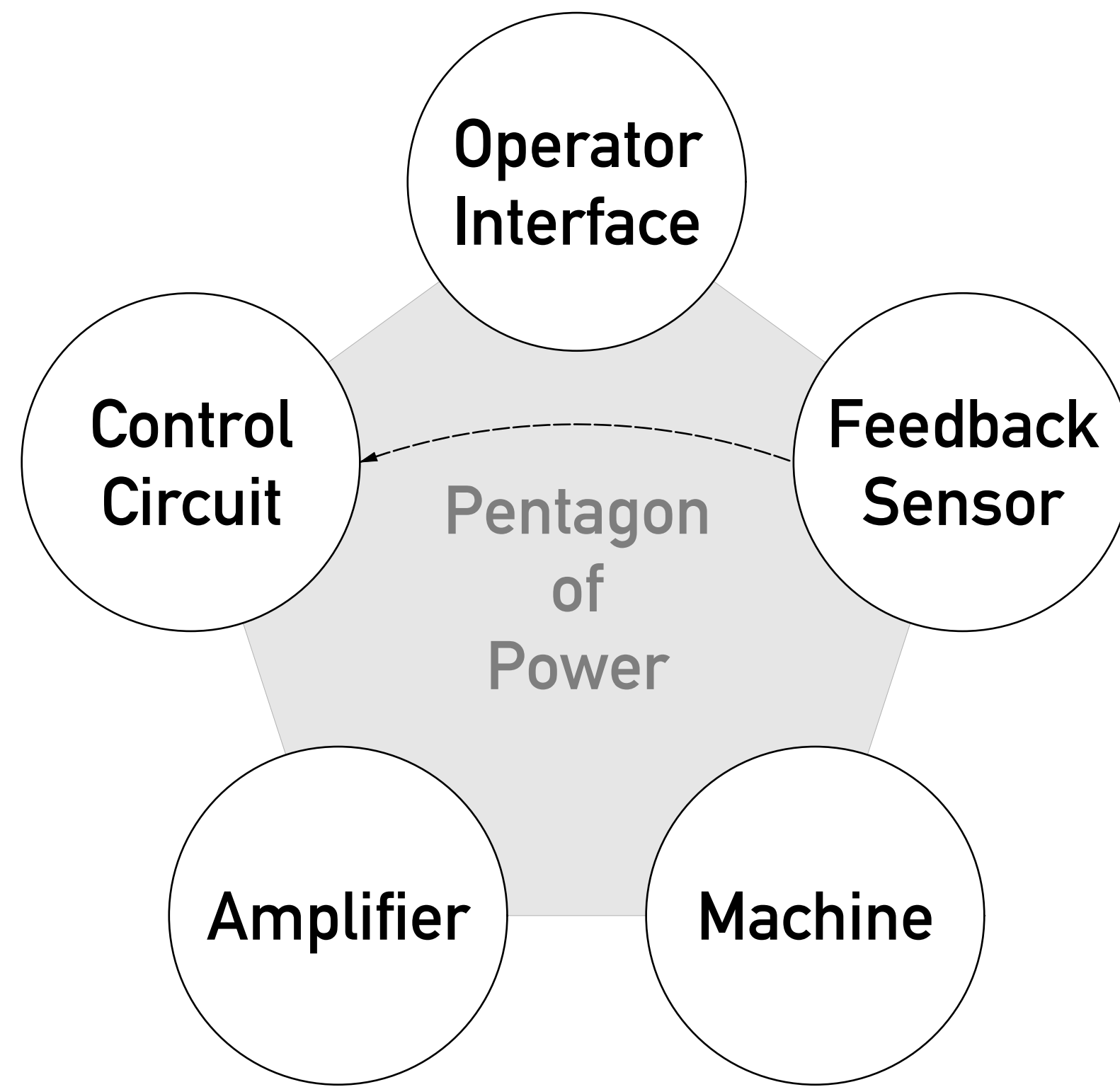

Luck Favors the Prepared

Save Time

...eventually

- Fewer staff
- Higher levels of training
- More time planning, less time operating



Sizing the Robot Army

- Number of Axes
- Horsepower



Number of Axes

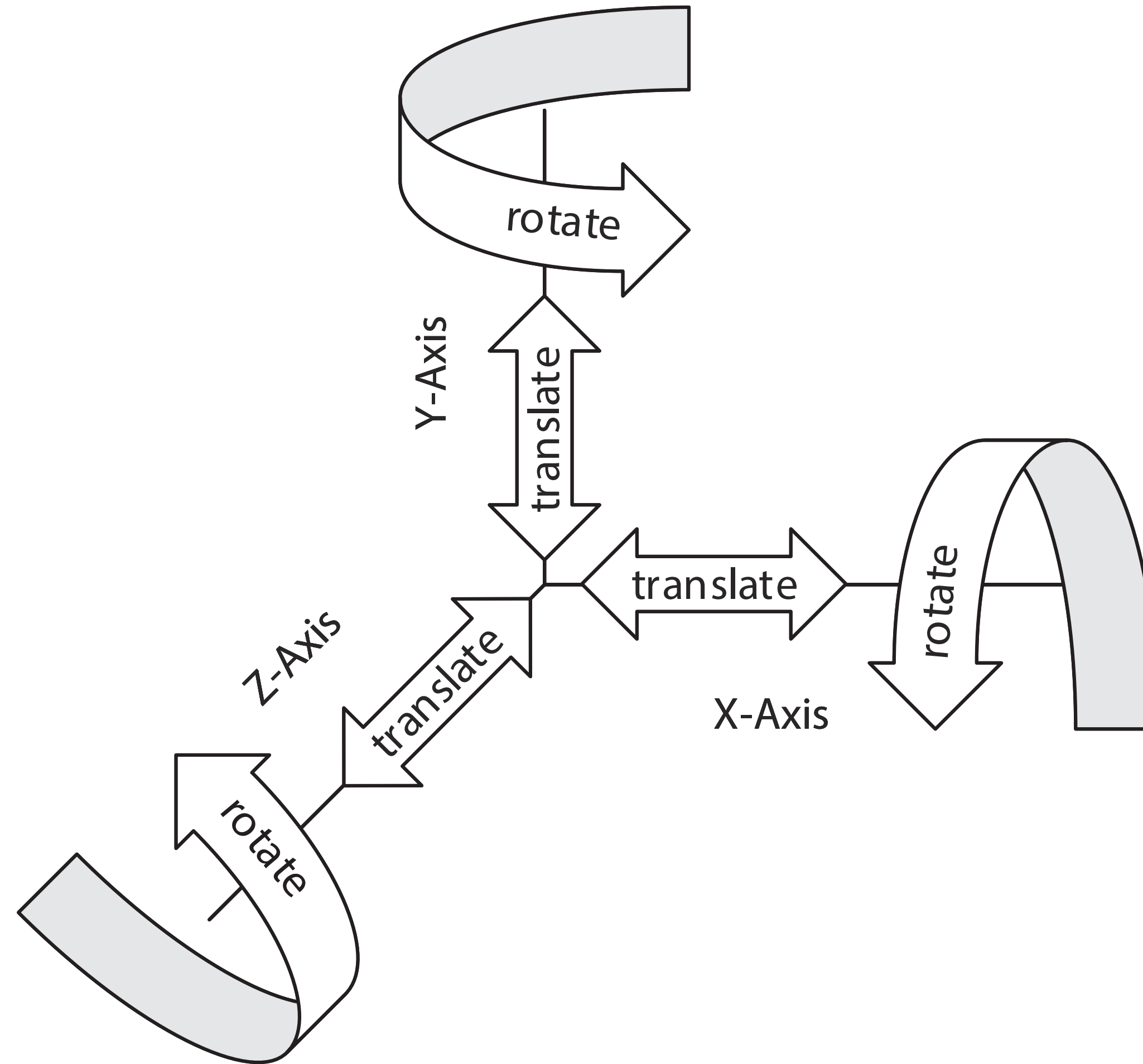

Horsepower

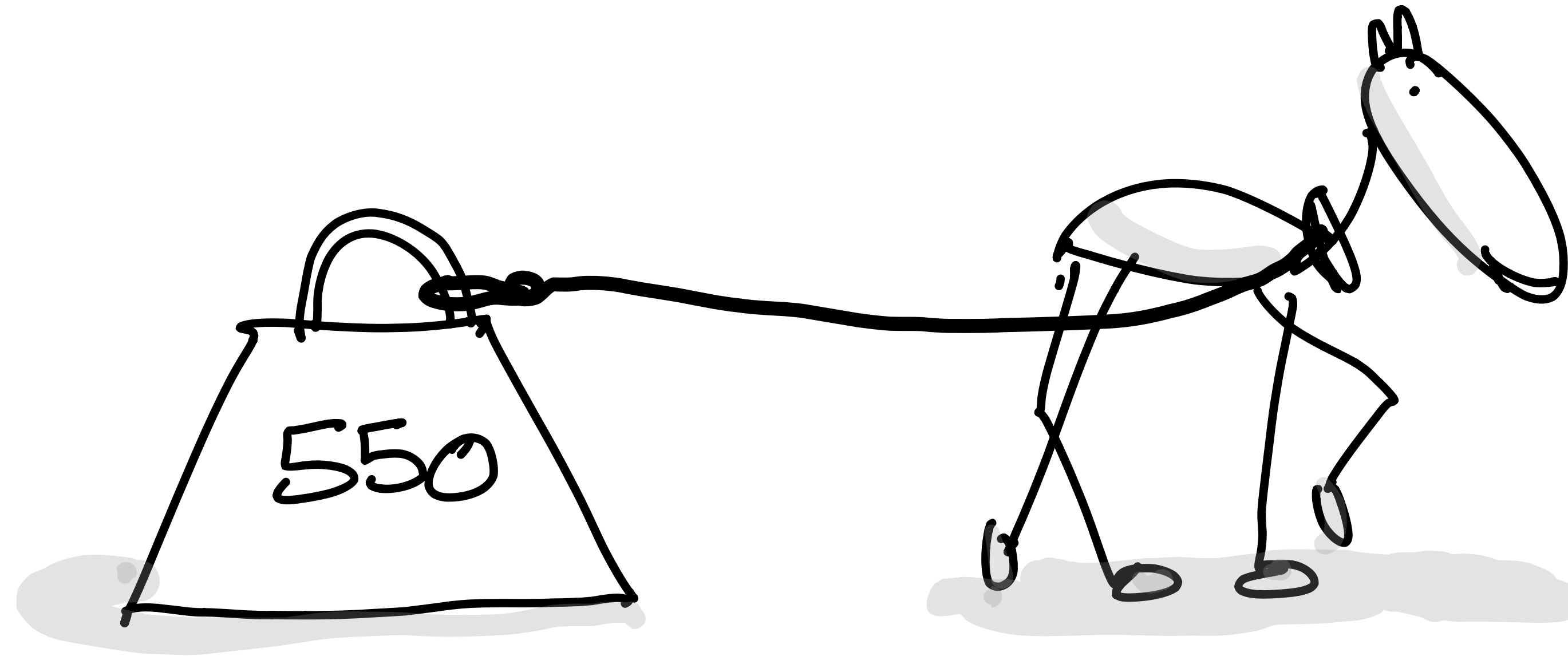

Speed = 1 ft/s

Motor Calc

<http://motorcalc.creativeconners.com>

Motor Calc

Creative Connors Inc.

Motor

Motor Horsepower: HP

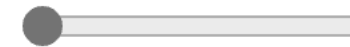

Motor Nameplate RPM: RPM



Speed Reduction

Speed Reducer Ratio: :1



Speed Reducer RPM: RPM



Speed Reducer Efficiency: %



Speed Reducer Torque: IN*LBS



Speed Reducer Sprocket: Teeth



Drum Sprocket: Teeth



Drum

Drum Diameter: IN



Drum Torque: IN*LBS

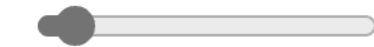

Pulling Force: LBS

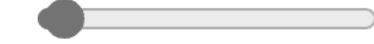

Linear Speed: IN/SEC



Provisioning the Robot Army

- Electrical requirements
- Cable pathways (both electrical and rigging)
- Supportive rigging for install
- Show decks



BOM							
Master Name	Horsepower	Length	Phase	Type	Voltage	Current	Quantity
Furman Strip							3
Network Cable - RJ45		10					2
Network Cable - RJ45		150					1
Network Cable - RJ45		50					17
Network Switch - 16P							3
Power Cable		75					16
Power Circuit			1-P		120VAC	15A	3
Power Circuit			1-P		208-230VAC	20A	15
Power Circuit			3-P		208-230VAC	30A	1
Pro Motor Cable		50		DEV			1
Pro/Apprentice Signal Cable		50		DEV			1
Showstopper Accessory Cable		10		DEV			1
Showstopper Accessory Cable		150		DEV			1
Showstopper Accessory Cable		50		DEV			1
Showstopper Base							1
Showstopper Cable		50					16
Showstopper Console							1
Showstopper Hub							2
Spikemark PC							1
Spotline							1
Spotline Mini							15
Stagehand Pro	5HP						1

Cable Connection Key	
N	Network
E	Showstopper
A	Showstopper Accessory
S	Machine Signal
M	Machine Motor
F	Limit - Forward
R	Limit - Reverse
P	Power
B	Interlock

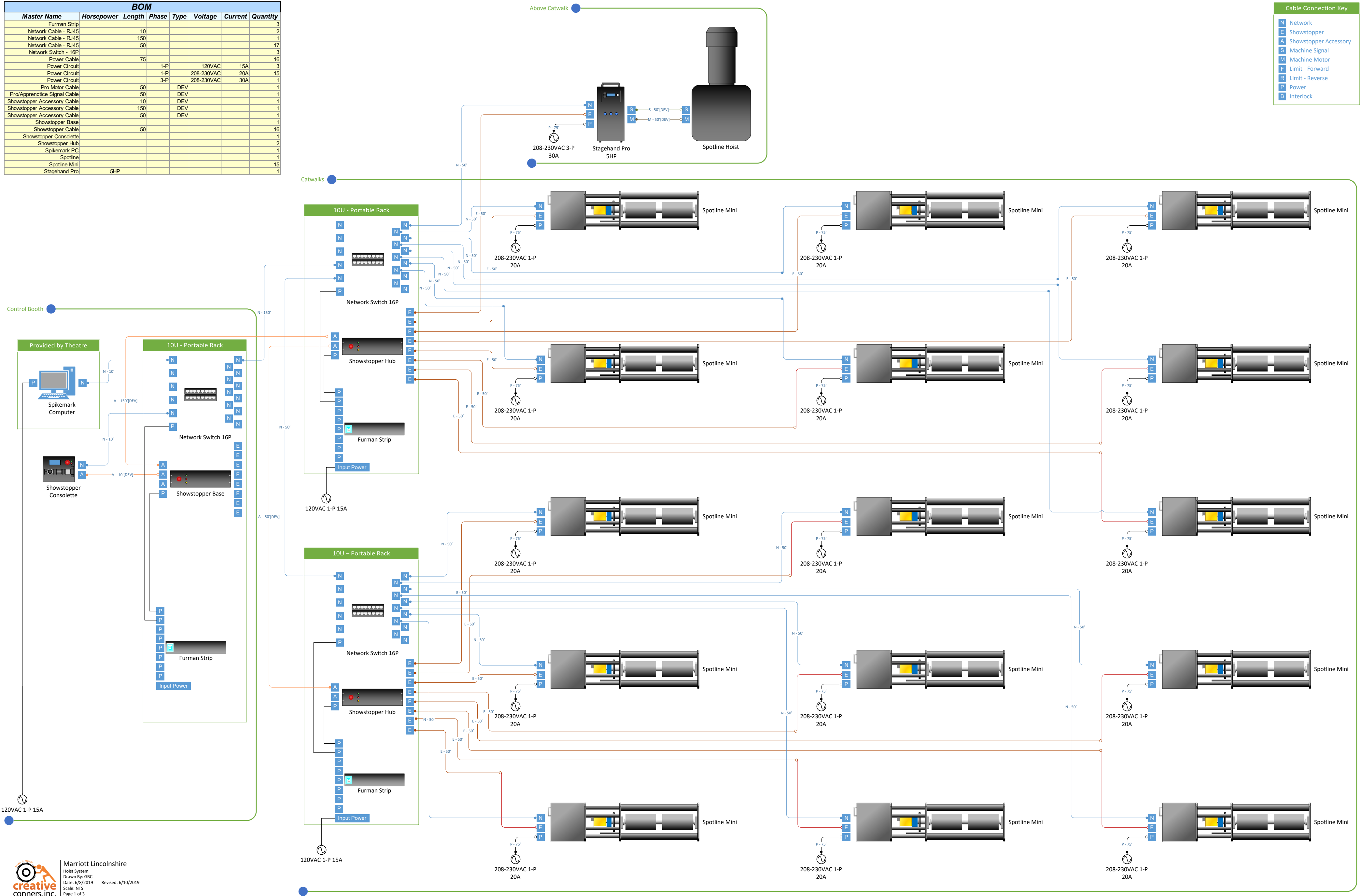

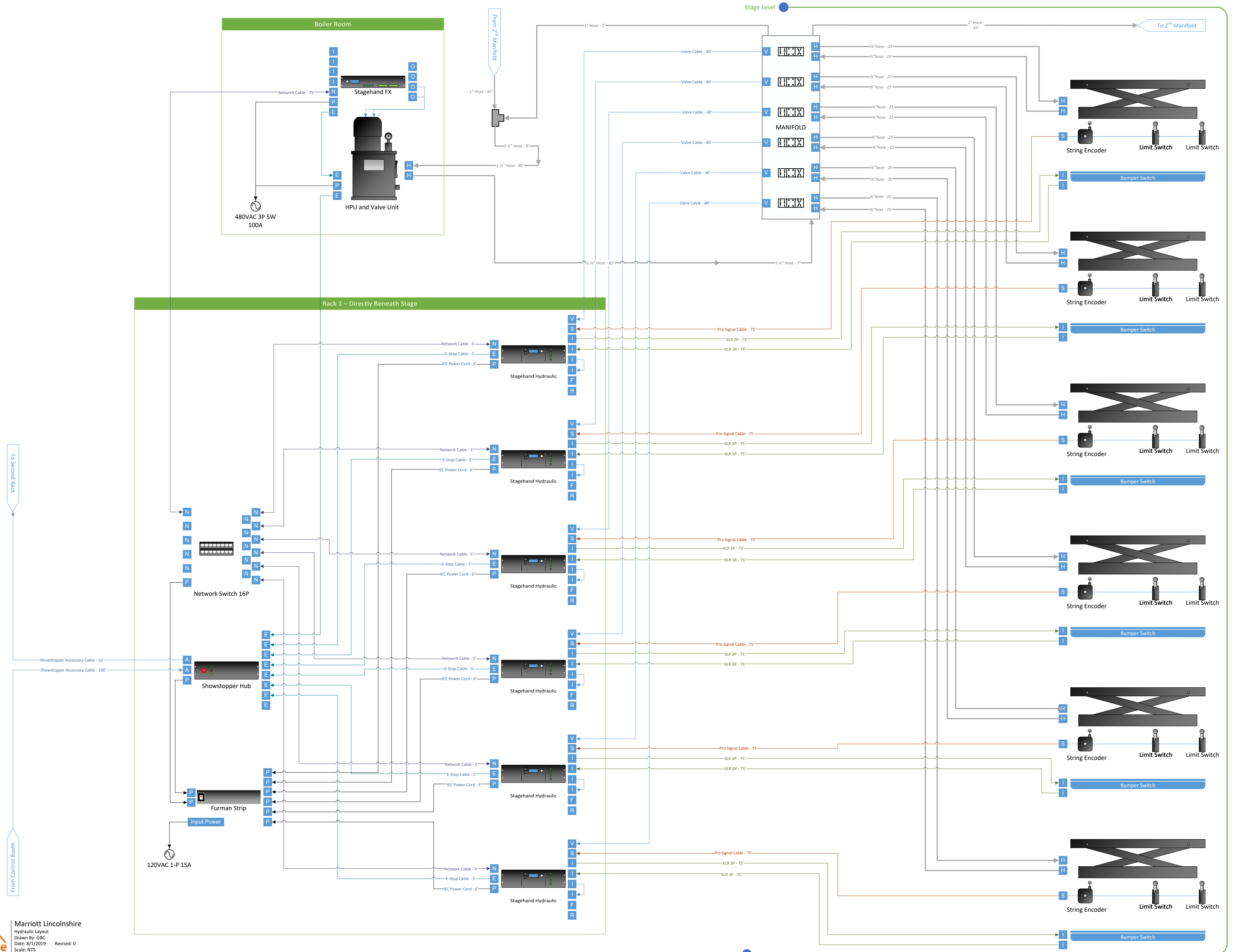

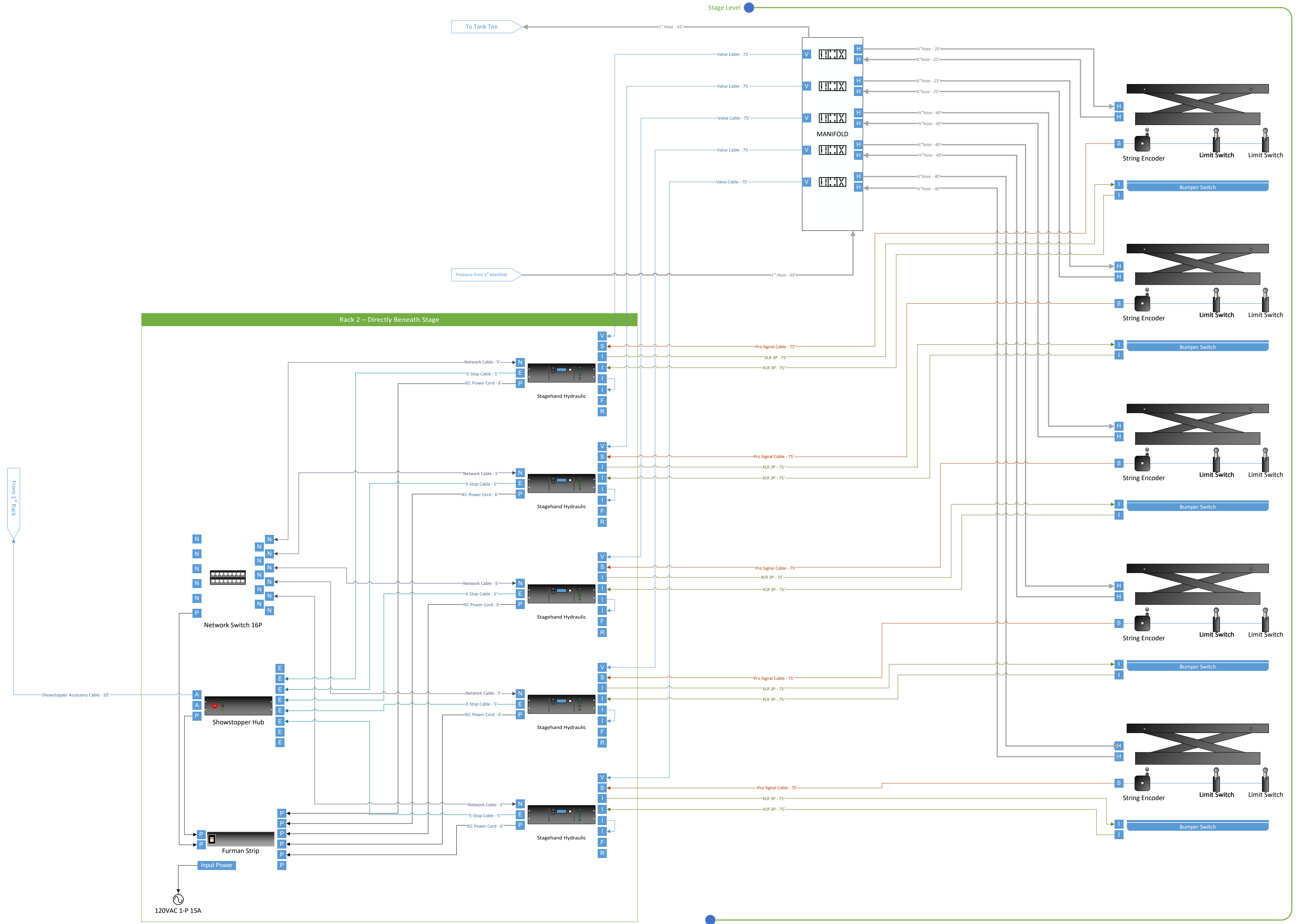

Scheduling Enough Time

At the right time

- Paper-tech & pre-viz
- Installation and commissioning
- Troubleshooting
- Programming
- Training



Keeping it Safe

- Identify the hazards and risks
- Remove them where possible
- Guard them when they can't be removed
- Protocols for safe habits
- Mix & match

A rectangular metal sign with a raised border, mounted on a metal post. The sign is silver and has the words "CAUTION", "ICE", and "FALLING" printed in bold, black, sans-serif capital letters, stacked vertically. The background is a blurred indoor setting with a wooden door or wall.

**CAUTION
ICE
FALLING**

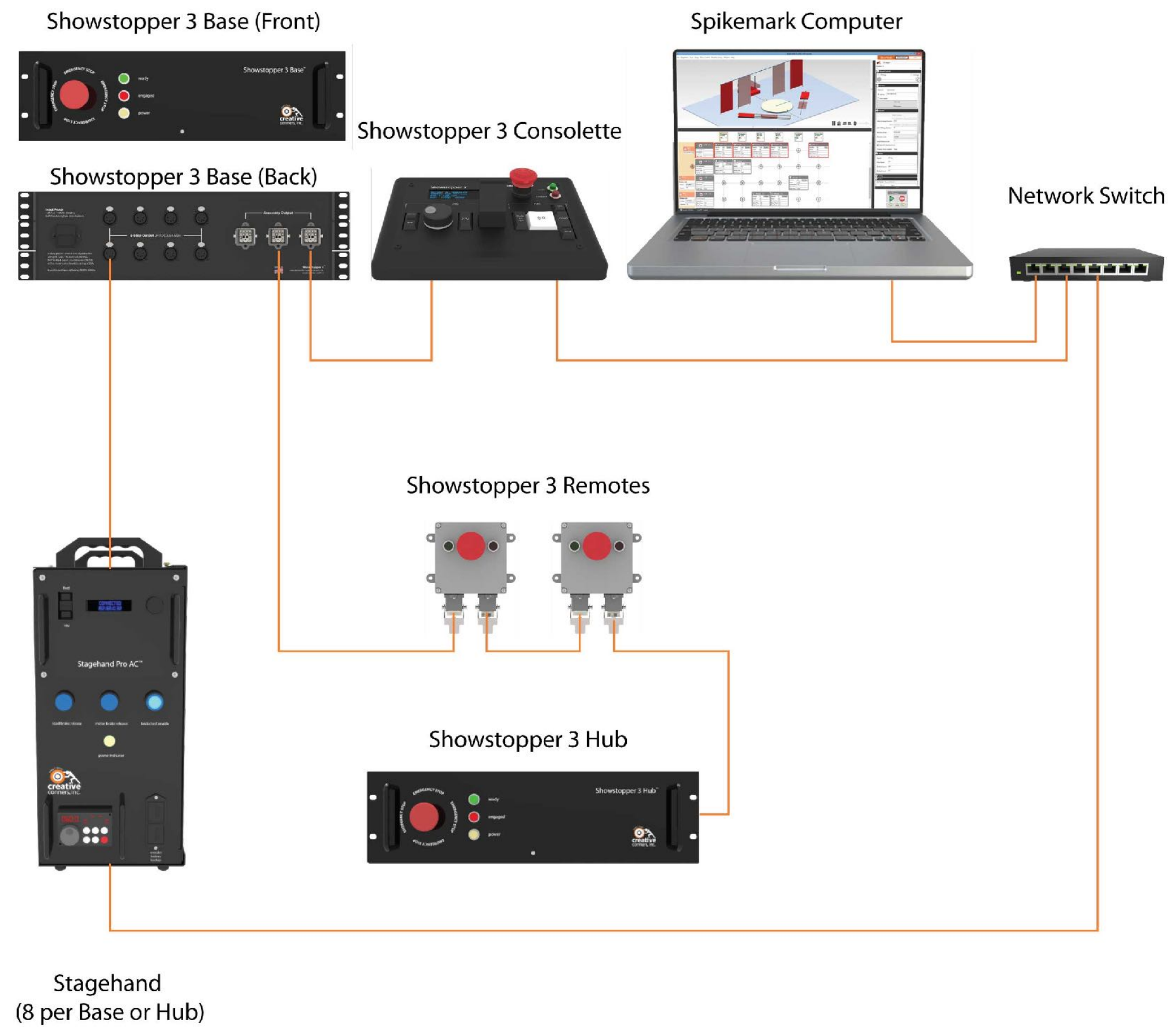

Emergency Stop is the Minimum

RARR

Risk Assessment and Risk Reduction

Product	Centrifuge Spinner
Completed By	Harry
Date	5/23/2021
Hazard Group	Entanglement
Hazard	Machine energized/moving while person is servicing machine.
Comment	
Severity	5
Probability	3
Risk Level	15
Risk Reduction Method	Lockable E-stop must be locked out to open access door. Beam break (plane) on interior of cylinder. 2nd E-stop locally at machine. Lock-out door latch. Latch should be openable from the inside
Severity	5
Probability	1
Residual Risk	5
Comment	

Risk Rating		Probability				
		Unlikely	Unlikely but Possible	Likely	Highly Possible	Certain
Severity of Harm	Trivial Injury	1	2	3	4	5
	Minor Injury	2	4	6	8	10
	3 day injury - loss of work	3	6	9	12	15
	Major Injury	4	8	12	16	20
	Death	5	10	15	20	25
	Risk Value	Acceptability				
1-4	Acceptable					
5-8	Acceptable only if risk is as low as reasonably practicable					
9-25	Unacceptable risk					

Product	Jesus Cross
Completed By	Kody G
Date	3/29/2019
Hazard Group	
Hazard	Pinch when loading Cross and Footrest
Comment	It's unclear how the horizontal member is attached, and how stiff the member is which affects the severity of injury. (Does the pipe bend rather than break fingers)
Severity	3
Probability	3
Risk Level	9
Risk Reduction Method	Additional interlock switches for when the cross/footrest is attached
Severity	3
Probability	1
Residual Risk	3
Comment	

Risk Rating		Probability				
		Unlikely	Unlikely but Possible	Likely	Highly Possible	Certain
Severity of Harm	Trivial Injury	1	2	3	4	5
	Minor Injury	2	4	6	8	10
	3 day injury - loss of work	3	6	9	12	15
	Major Injury	4	8	12	16	20
	Death	5	10	15	20	25
	Risk Value	Acceptability				
1-4	Acceptable					
5-8	Acceptable only if risk is as low as reasonably practicable					
9-25	Unacceptable risk					

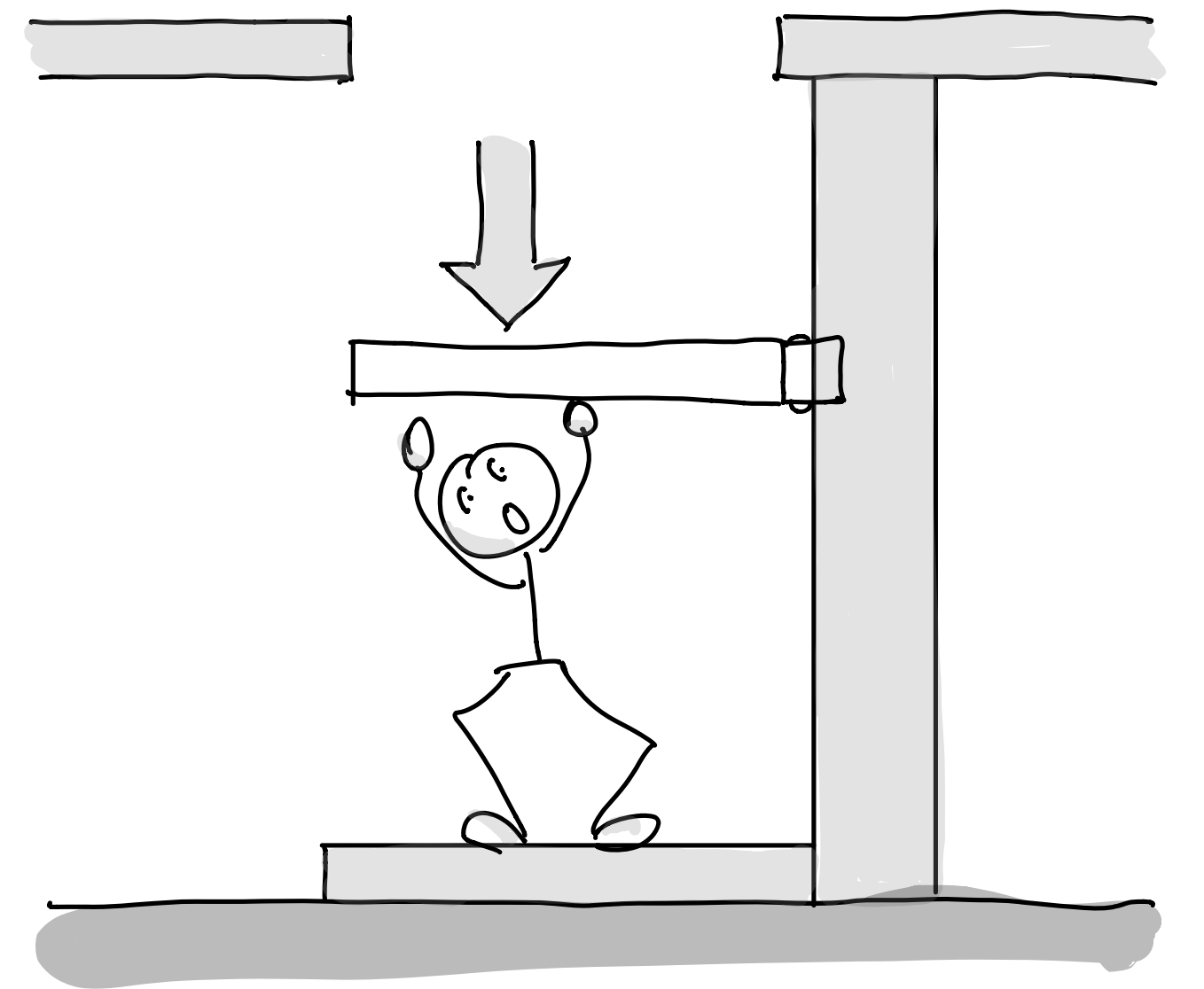
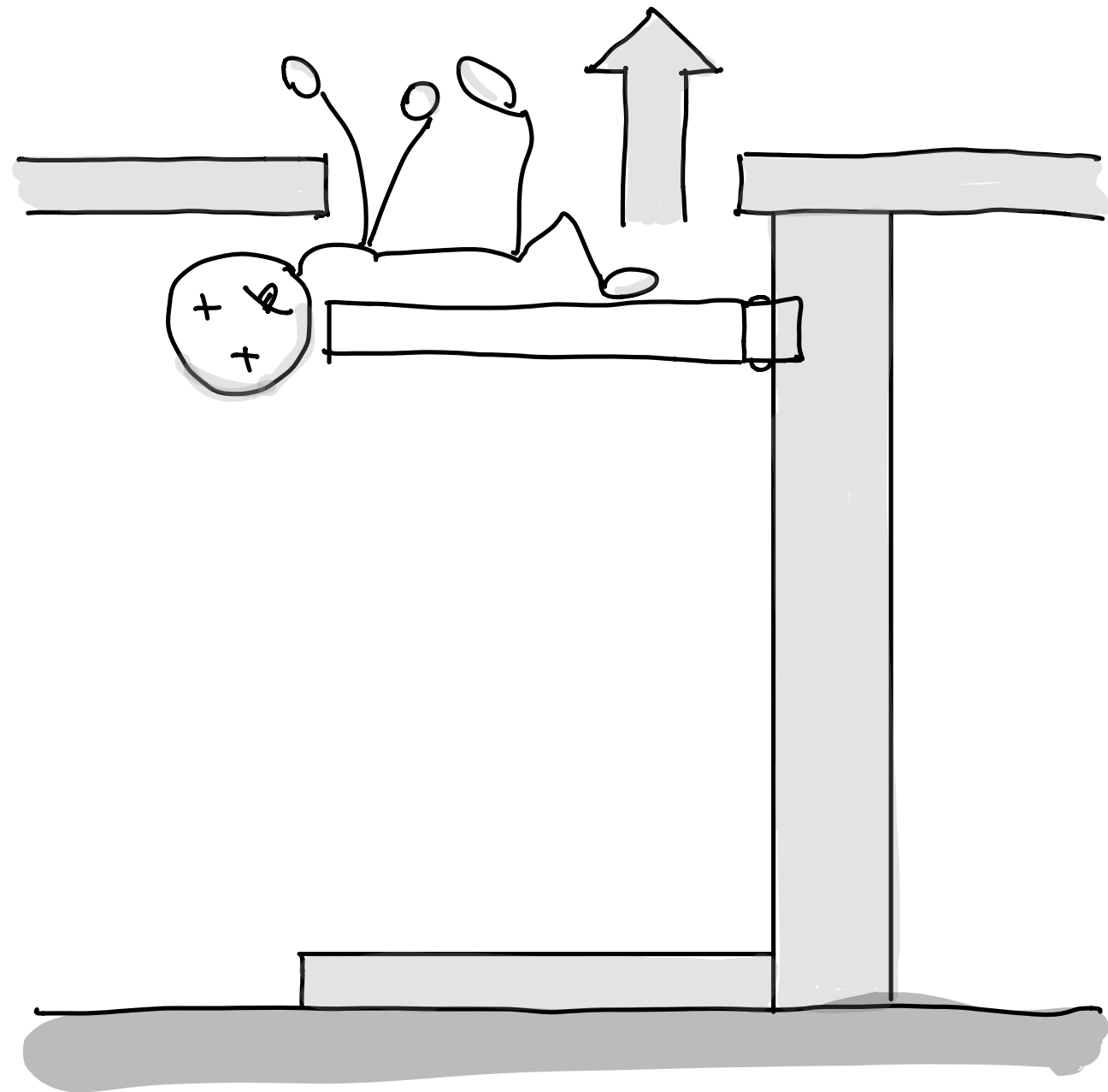
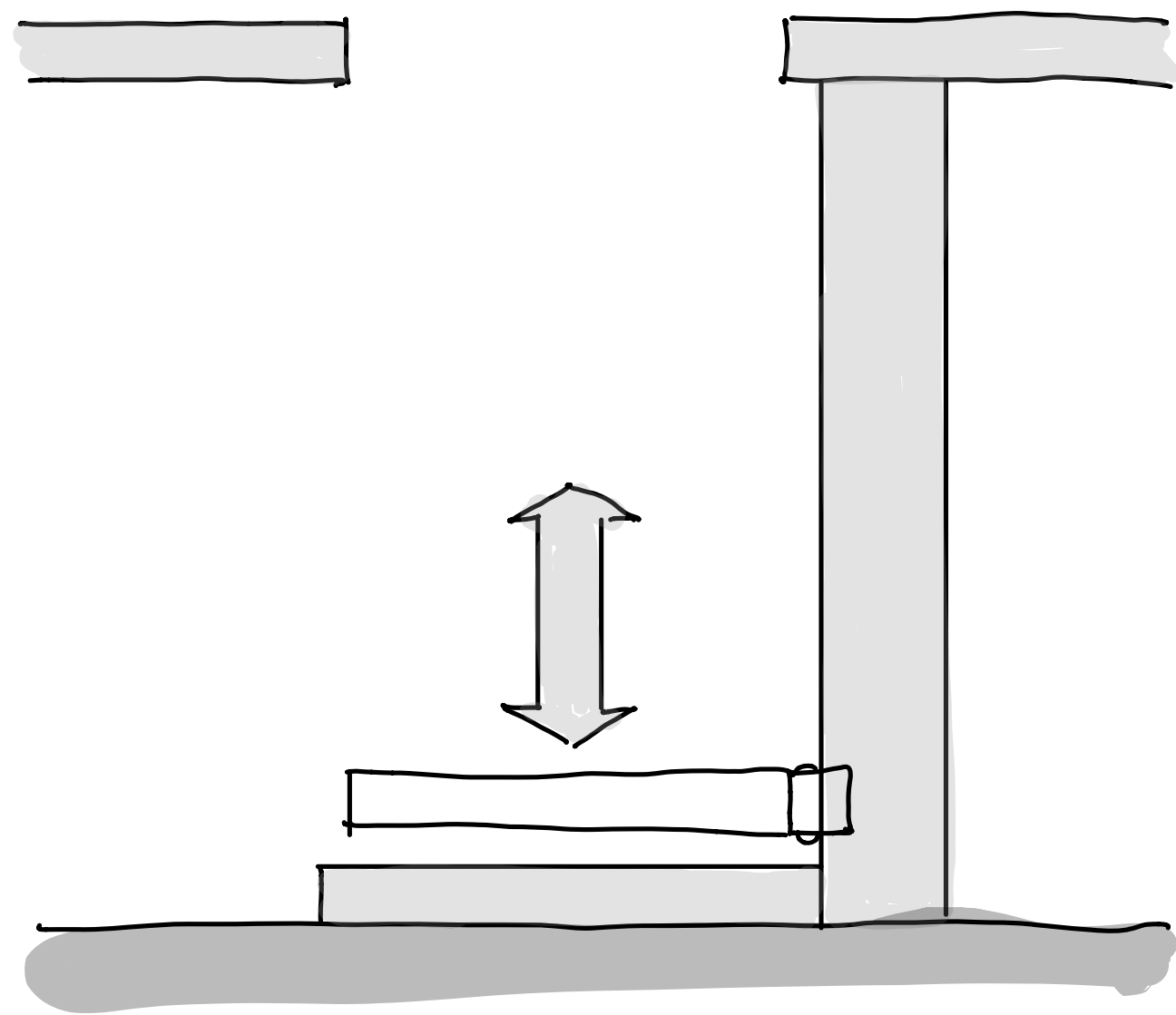



**Sensing Edge Switches
When Compressed**

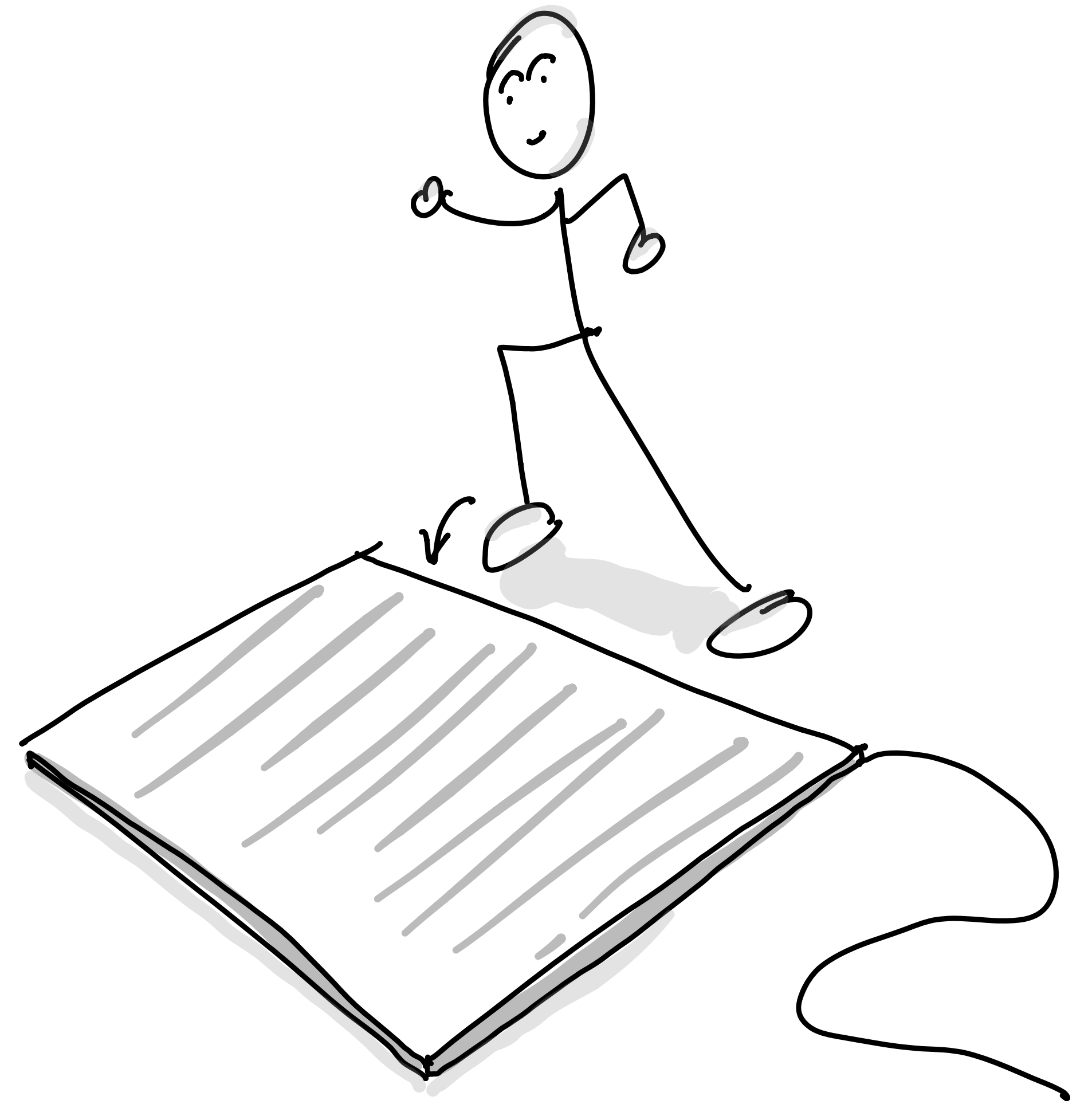

Safety Mat Activates with Pressure

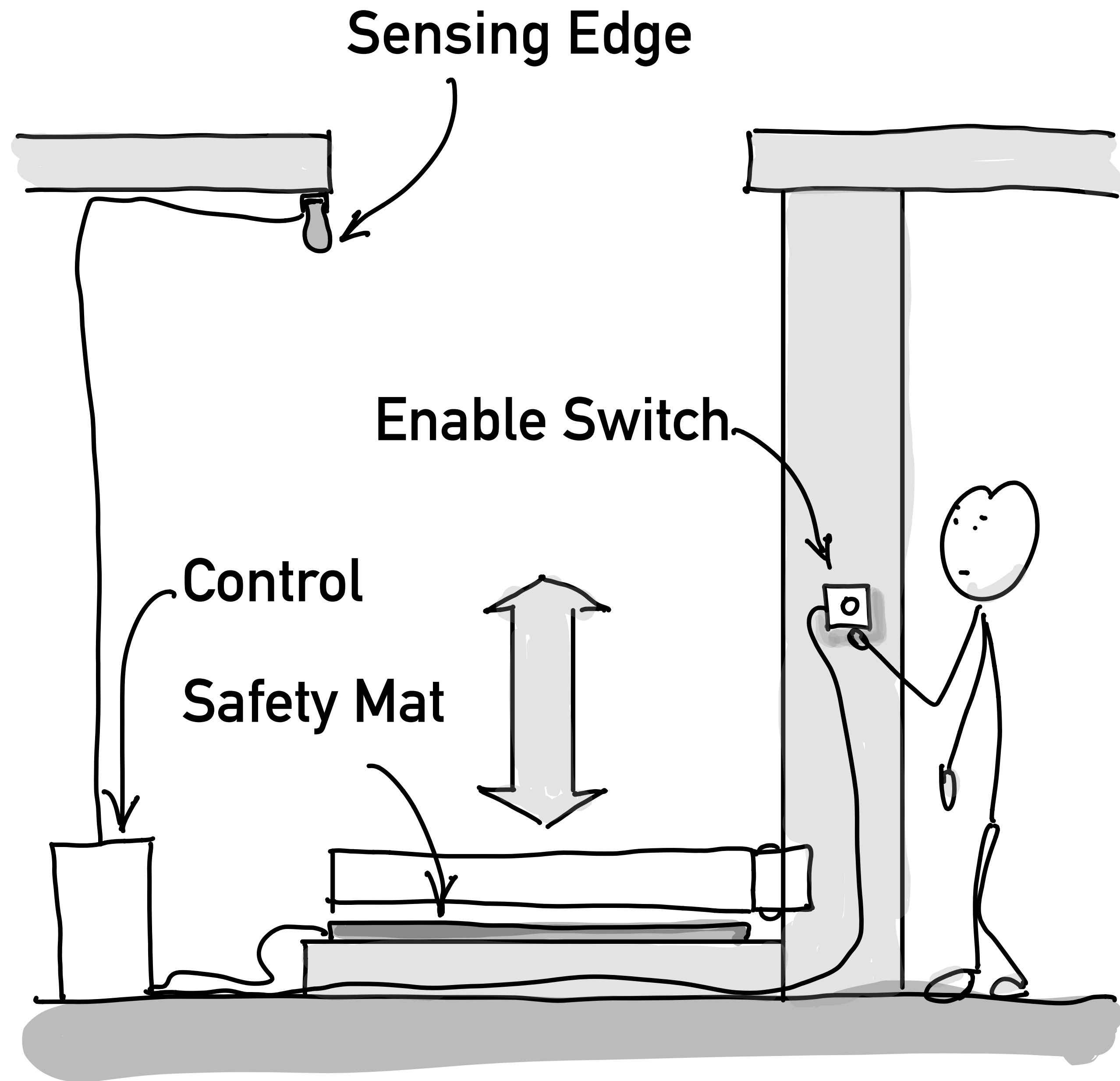

Critical Concepts

Fail-safe • Redundancy • Fault-tolerant

Learn More
Scenic Automation
Handbook

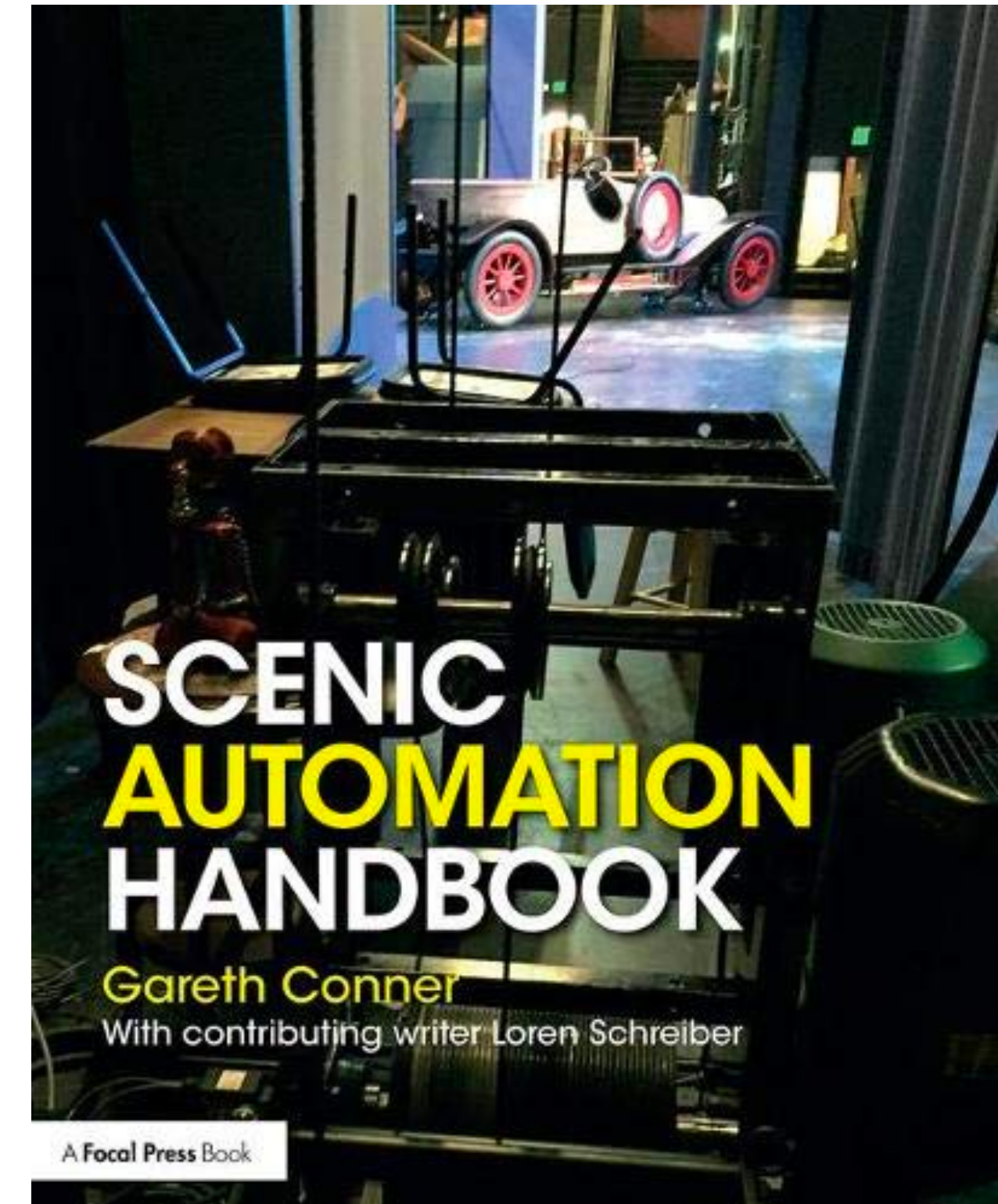

Thanks

And good luck!